

R

**Reparaturanleitung
Repair Instructions**



**A11VO 40 ... 95
LRDS**

Baureihe 1 / Series 1



HINWEIS

Bezeichnungen, Beschreibungen und Darstellungen entsprechen dem Informationsstand zum Zeitpunkt der Drucklegung dieser Unterlage.

Änderungen können den Service am Produkt beeinflussen, Verpflichtungen entstehen uns daraus nicht. Methoden und Vorrichtungen sind Empfehlungen, für deren Resultat wir keine Haftung übernehmen können.

HYDROMATIK- Baugruppen, mit Angabe der Fabrik-Nr. bestellt, sind die Basis guter Reparaturen.

Einstell- und Prüfarbeiten sind bei Betriebstemperatur auf dem Teststand vorzunehmen.

Schutz von Personen und Eigentum ist durch Vorkehrungen sicherzustellen.

Sachkenntnis, die Voraussetzung für jede Servicearbeit, vermitteln wir in unseren Schulungskursen.

NOTICE

Specifications, descriptions and illustrative material shown herein were as accurate as known at the time this publication was approved for printing.

HYDROMATIK reserves the right to discontinue models or options at any time or to change specifications, materials, or design without notice and without incurring obligation.

Optional equipment and accessories may add cost to the basic unit, and some options are available only in combination with certain models or other options.

For the available combinations refer to the relevant data sheet for the basic unit and the desired option.

Adjustment and tests have to be carried out on the test bench under operating temperatures.

Protection of personnel and property has to be guaranteed by appropriate measures.

Expert knowledge, the precondition of any service work, can be obtained in our training courses.

INHALT**Seite/
Page****A11VO 60 LRDS**

Schnittbild	3
Allgemeine Reparaturhinweise	4
Baugruppen	5-6
Triebwelle abdichten	7
Reglergehäuse abdichten	8
Anschlußplatte, Regler demontieren	9-11
Triebwerk ausbauen	12-14
Überprüfungshinweise	15-17
Pumpe montieren	18-22
Anziehdrehmomente	23

CONTENTS**A11VO 60 LRDS**

Sectional view
General repair instructions
Sub assemblies
Sealing of the drive shaft
Sealing of the regulator housing
Remove port plate, regulator
Remove rotary group
Inspection notes
Pump assembly
Tightening torques

A11VO...LRDS

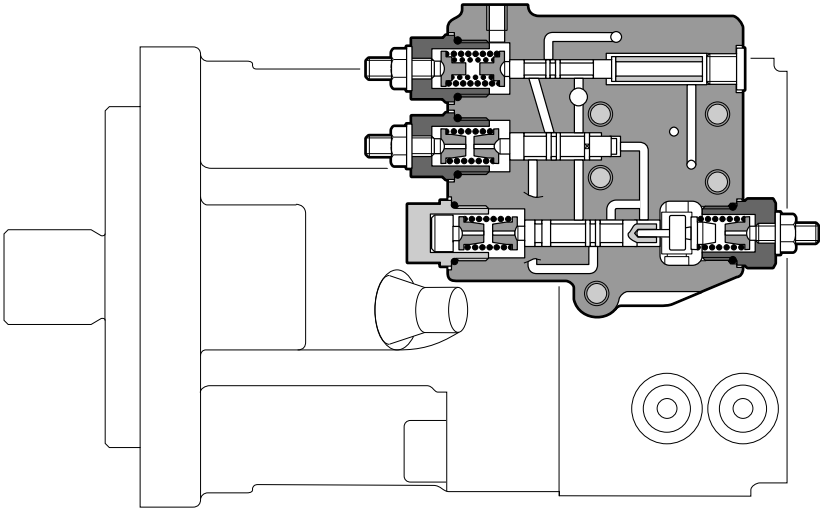
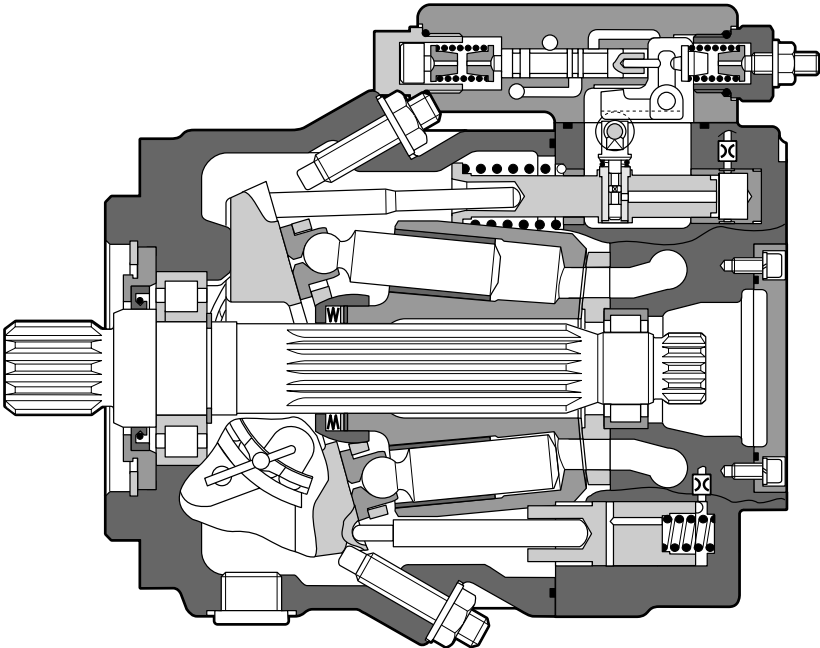

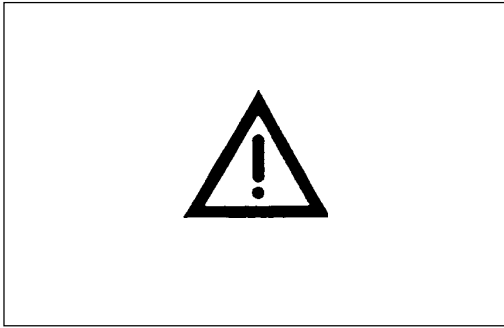

Achtung!
Nachfolgend Hinweise bei allen Reparaturarbeiten an Hydraulikaggregaten beachten!

Attention!
Observe the following notices when carrying out repair work at hydraulic aggregates!

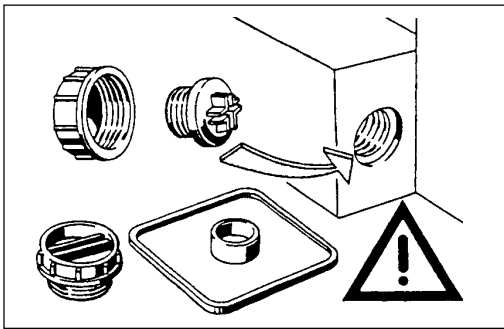

Alle Öffnungen der Hydraulikaggregate verschließen.

Close all ports of the hydraulic aggregates.

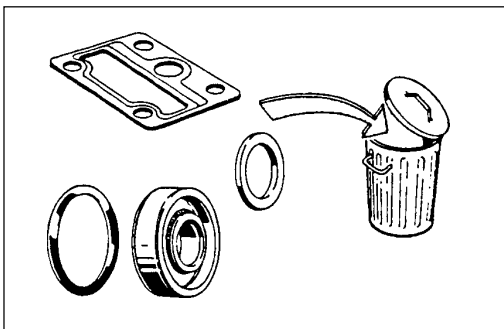

Alle Dichtungen erneuern.
Nur original HYDROMATIK-Ersatzteile verwenden.

Replace all seals.
Use only original HYDROMATIK spare parts.

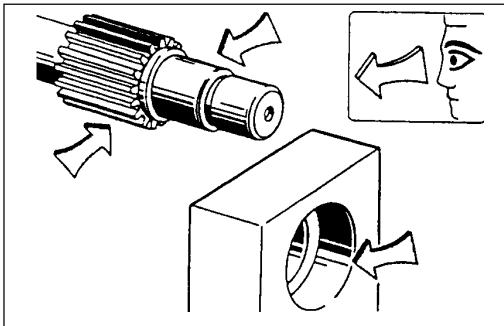

Alle Dicht- und Gleitflächen auf Verschleiß prüfen.
Achtung: Nacharbeiten an Dichtflächen z.B. durch Schleifpapier kann die Oberfläche beschädigen.

Check all seal and sliding surfaces for wear.
Attention: Rework of sealing area f. ex. with abrasive paper can damage surface.

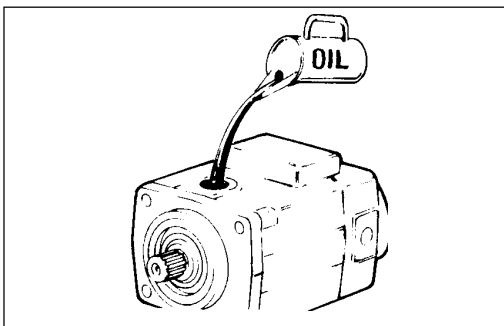

Hydraulikaggregate vor Inbetriebnahme mit Hydrauliköl befüllen.

Fill up hydraulic aggregates with hydraulic oil before start-up.

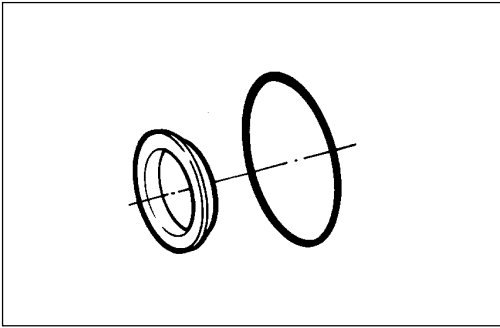

- 1 Dichtsatz für Triebwelle.
Seal kit for drive shaft.

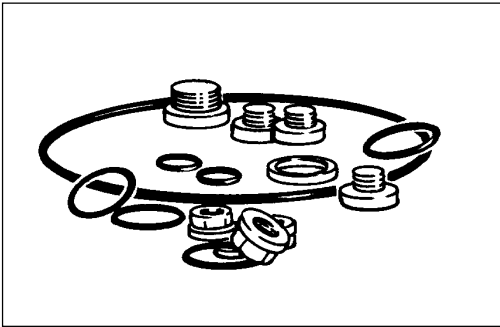

- 2 Äußerer Dichtsatz.
External seal kit.

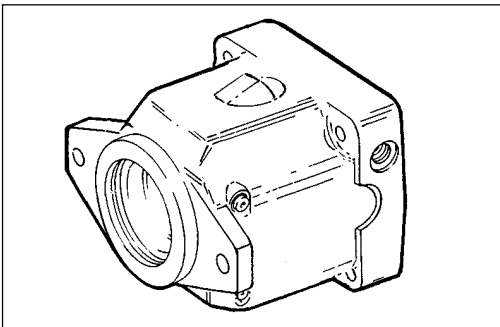

- 3 Gehäuse
Housing

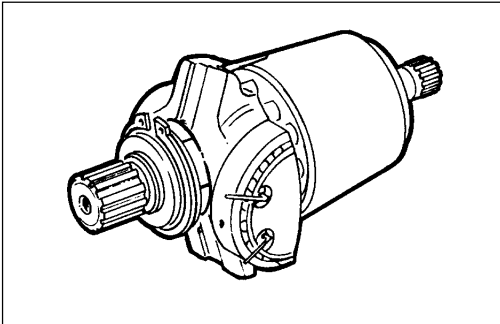

- 4 Triebwerk komplett.
Complete rotary group.

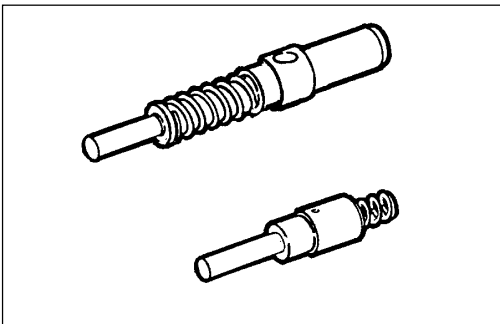

- 5
1. Verstellung klein
2. Verstellung groß
1. Hydraulic control small size
2. Hydraulic control big size

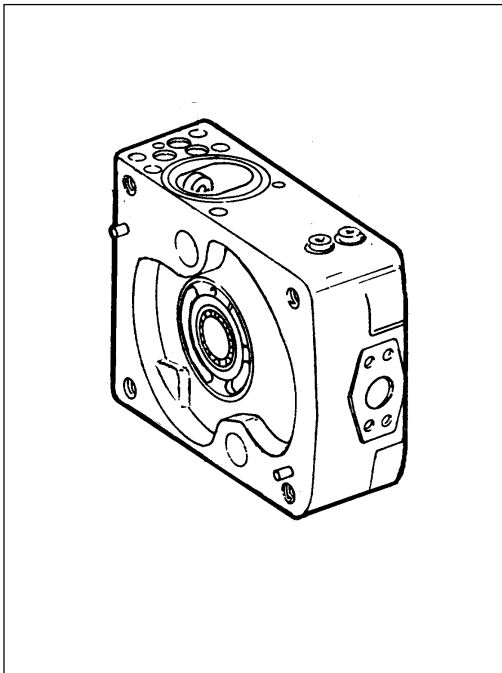

6 Anschlußplatte
Valve plate

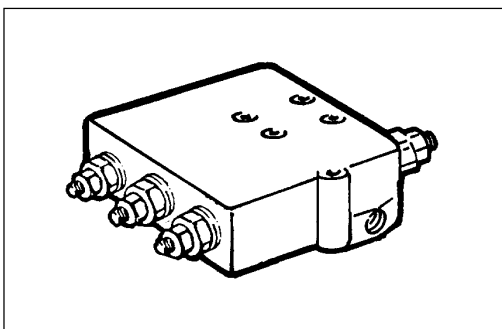

7 Regler komplett
Complete regulator

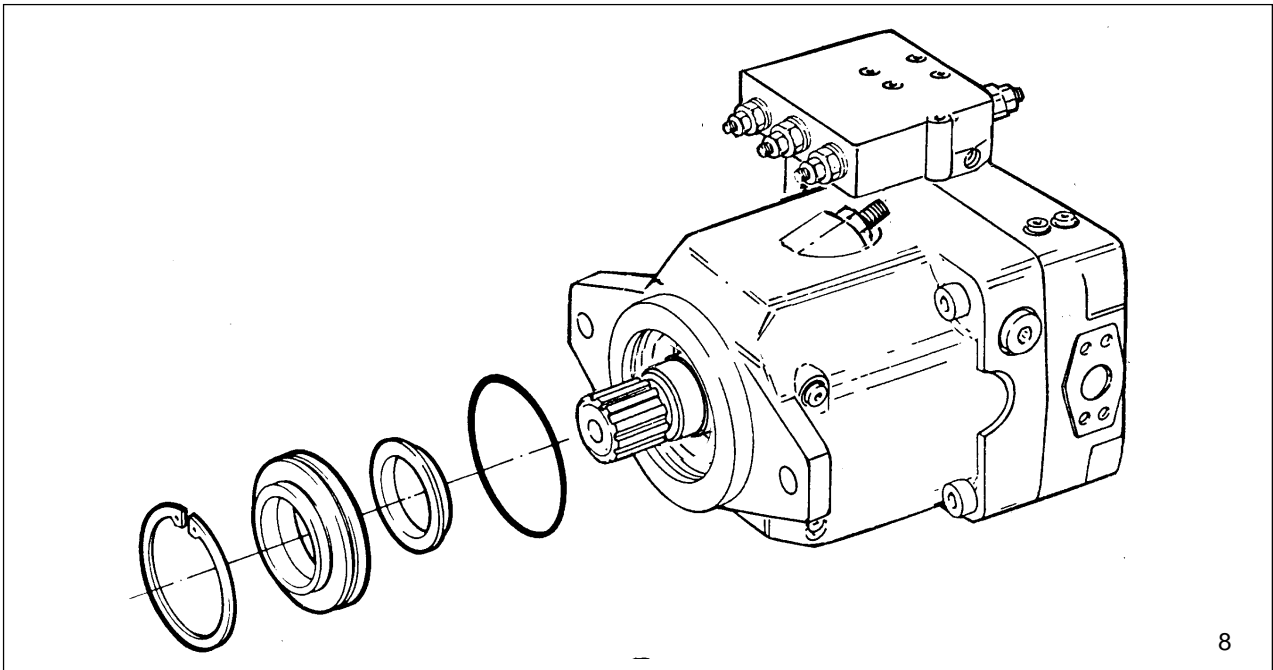

8

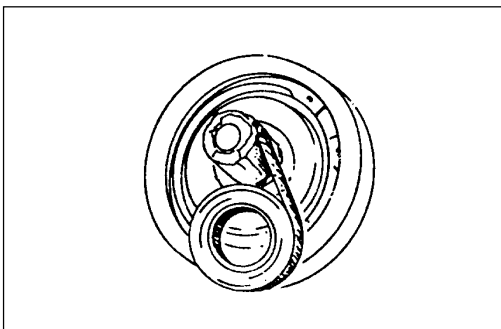

- 9 Treibwelle abkleben.
Protect the drive shaft.

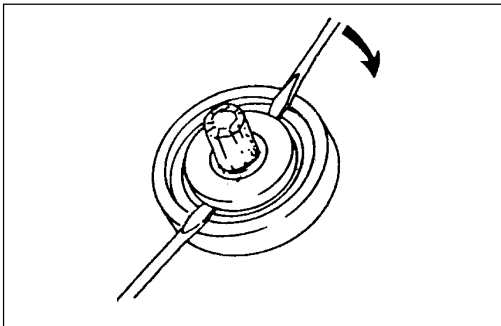

- 10 Sicherungsring lösen und ausbauen.
Verschlußring abdrücken.
Loosen retaining ring and remove it,
press away front cover.

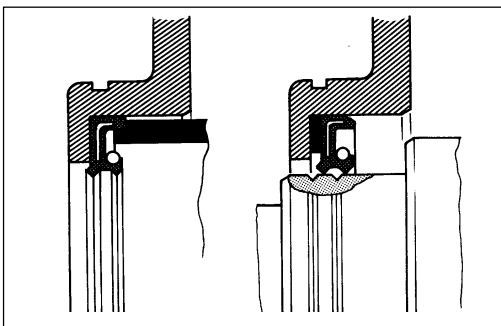

- 11 1. Neuen Wellendichtring lagerichtig mit passender
Büchse einpressen.
2. Bei tiefer Laufrille Scheib vor den
Wellendichtring einlegen.

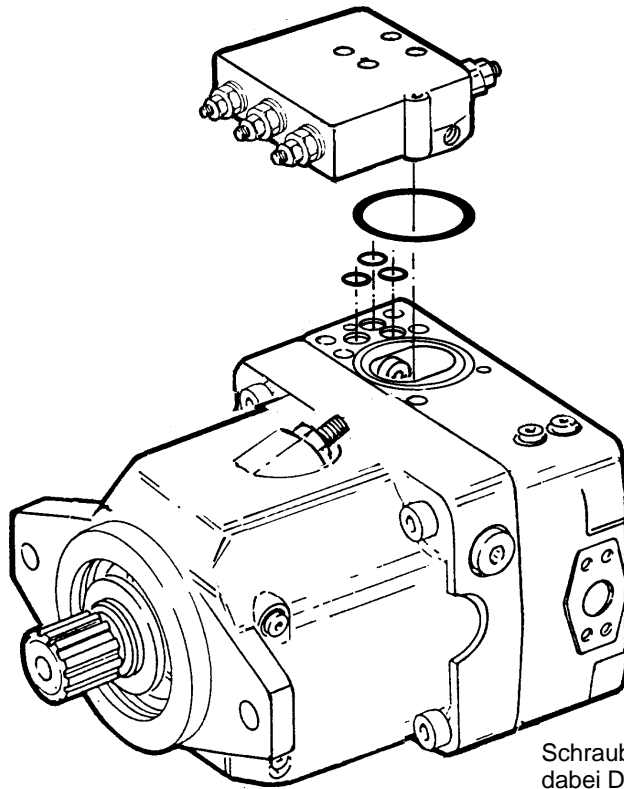

Schrauben ausbauen und Regler abdrücken, dabei Dichtfläche nicht beschädigen.

Remove screws and press off regulator, thereby make sure that sealing surface is not damaged.

12

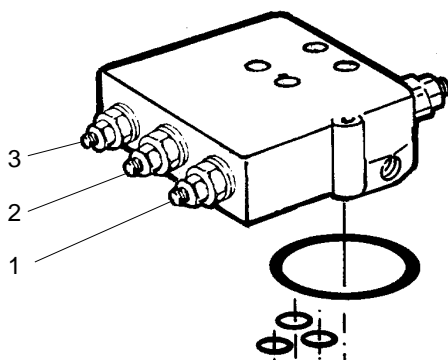

1. Leistungsregler
2. Druckregler
3. Load-Sensing-Regler

Achtung!

Einstellschrauben nicht verändern. Gewindehülse komplett mit Einstellschrauben ausbauen.

1. Power control
2. Pressure control
3. Load-Sensing valve

Note:

Do not change position of adjustment screws. Remove complete set of threaded bush with adjustment screws.

13

Anschlußplatte, Regler demontieren
Remove port plate, regulator

Reparaturanleitung A11VO
Repair Instructions A11VO

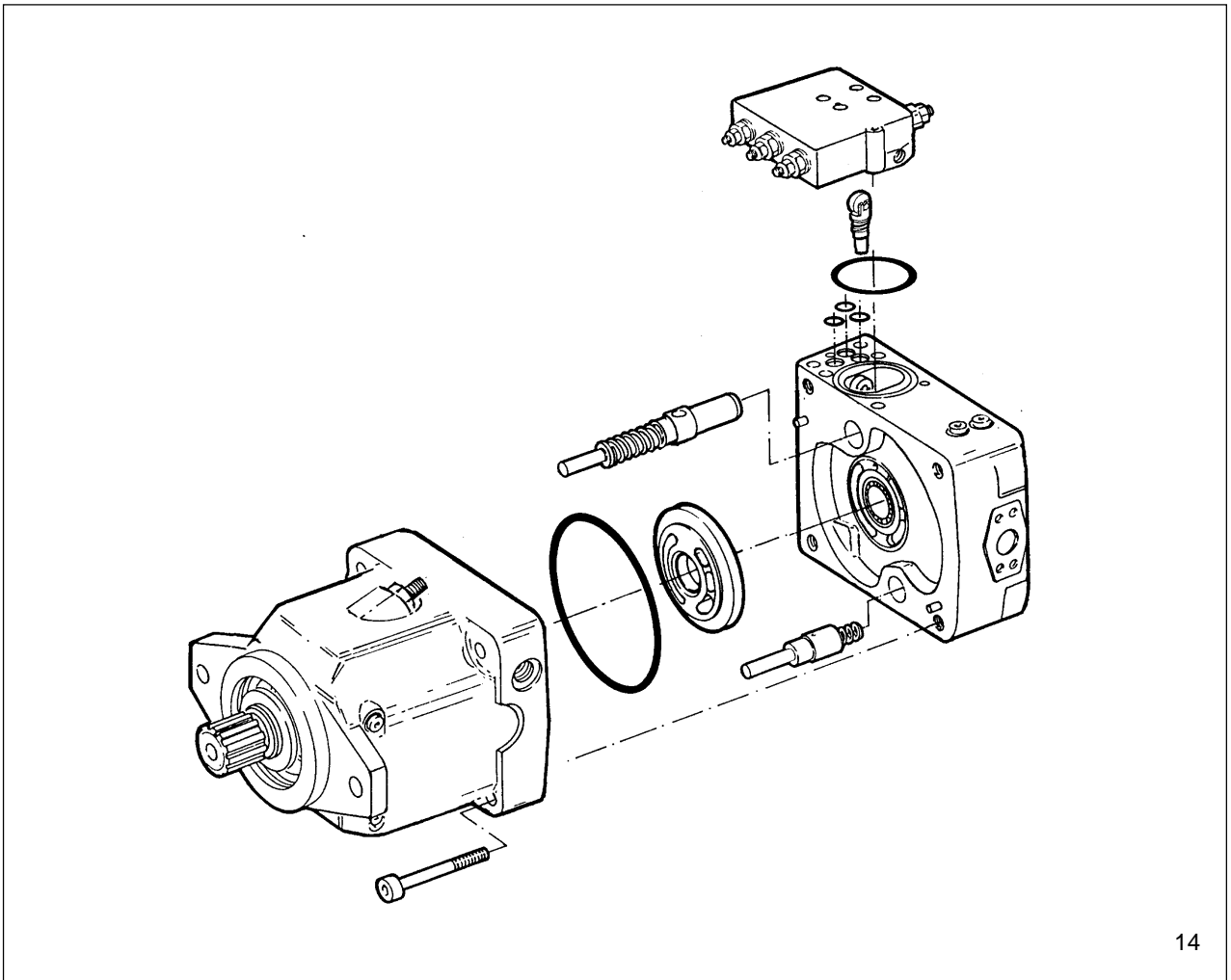

14

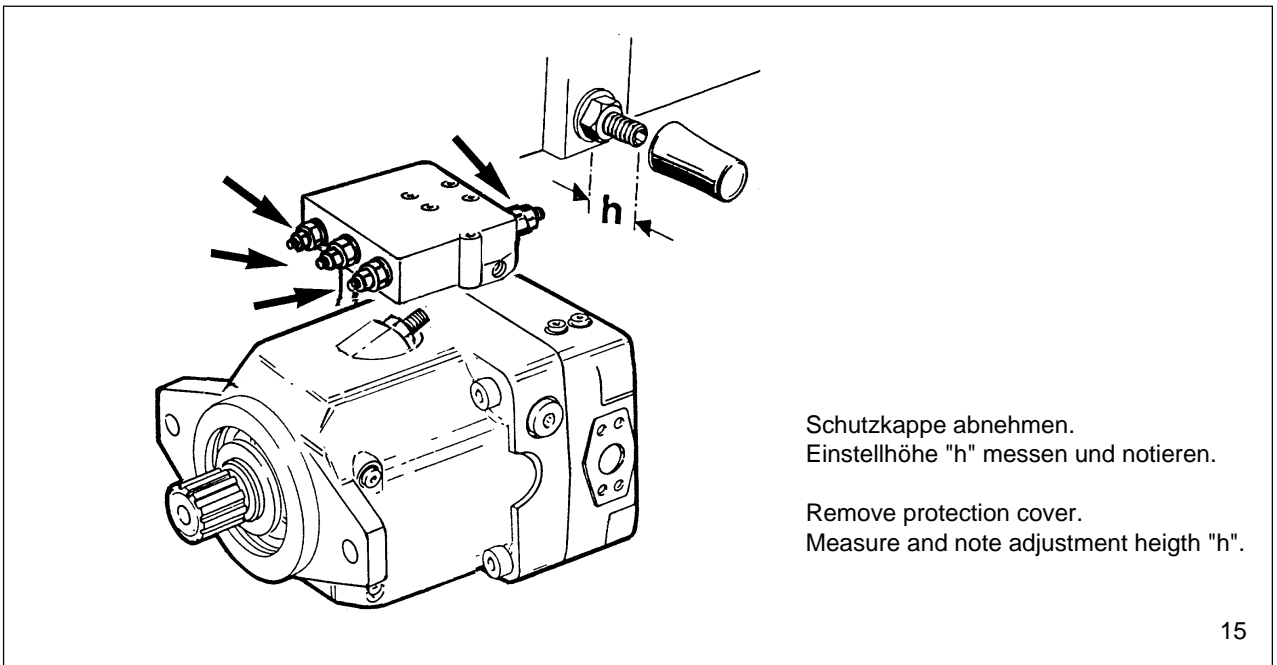

15

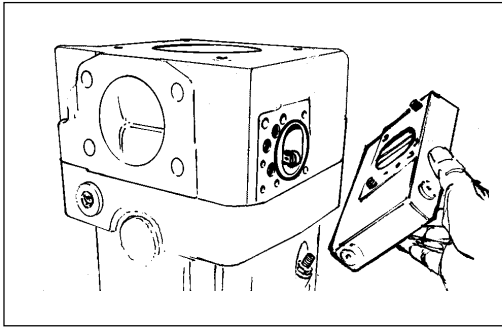

- 16 Reglergehäuse abbauen.
Remove regulator housing.

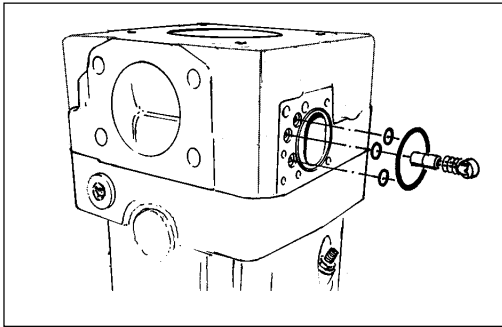

- 17 O-Ringe, Meßkolben mit Büchse und Feder ausbauen.
Remove O-rings, measuring piston with bush and spring.

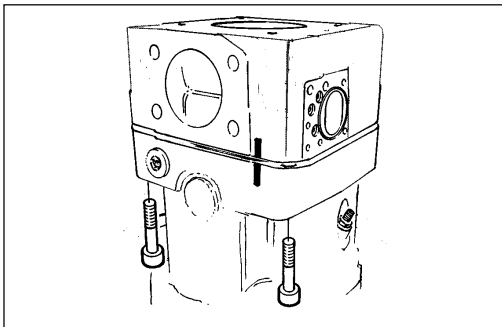

- 18 Lage der Anschlußplatte markieren.
Anschlußplattenbefestigung lösen.
Mark position of the connection plate.
Loosen connection plate fixation.

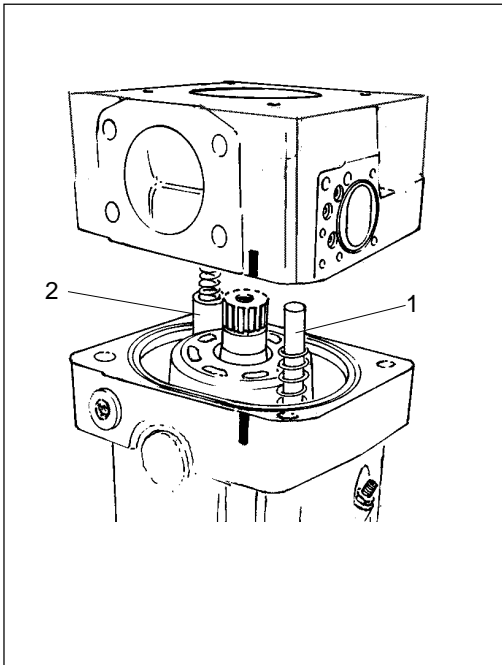

- 19 Anschlußplatte mit Steuerplatte abheben.
Verstellung ausbauen.
1. Hydr.- klein
2. Hydr.- groß
Remove port plate with control plate.
Disassemble regulator.
1. Hydr.- small
2. Hydr.- large

Anschlußplatte, Regler demontieren
Remove port plate, regulator

Reparaturanleitung A11VO
Repair Instructions A11VO

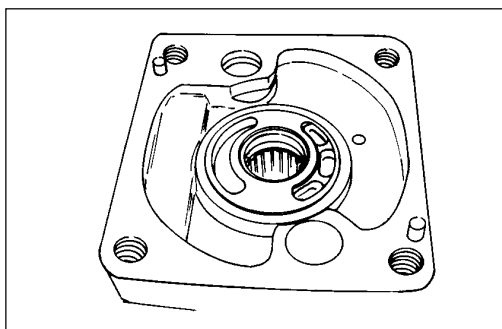
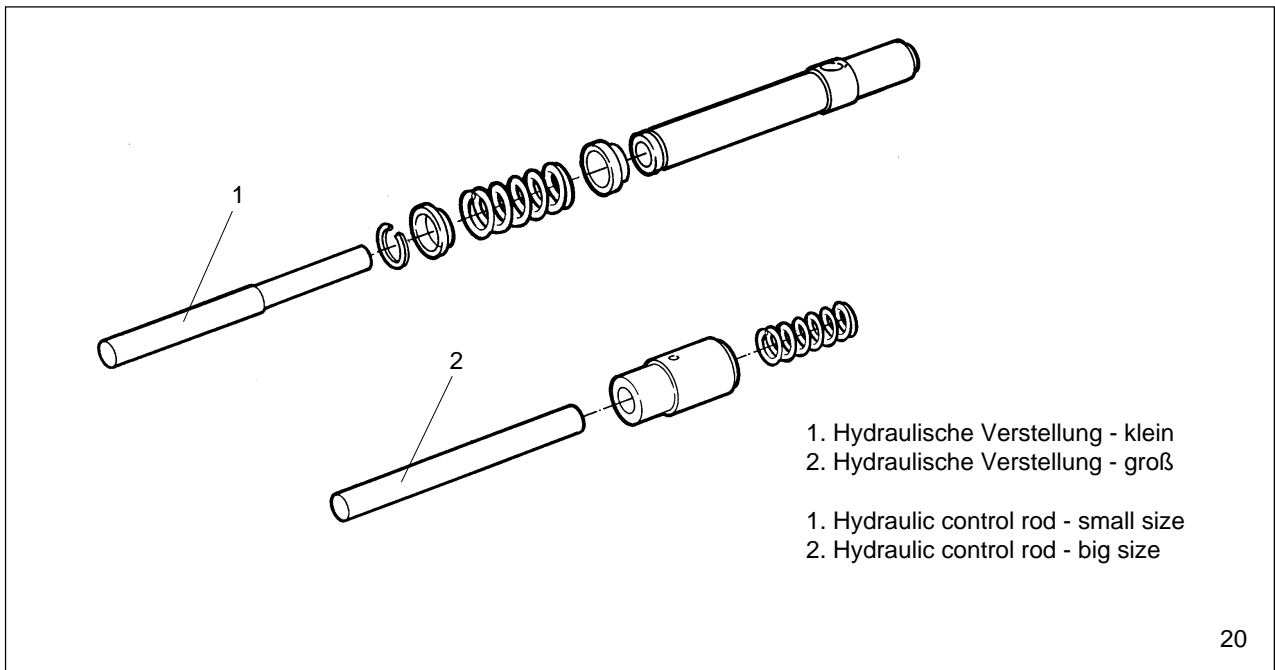

21 Steuerplatte ausbauen.
Lage kennzeichnen.

Remove control plate.
Mark position.

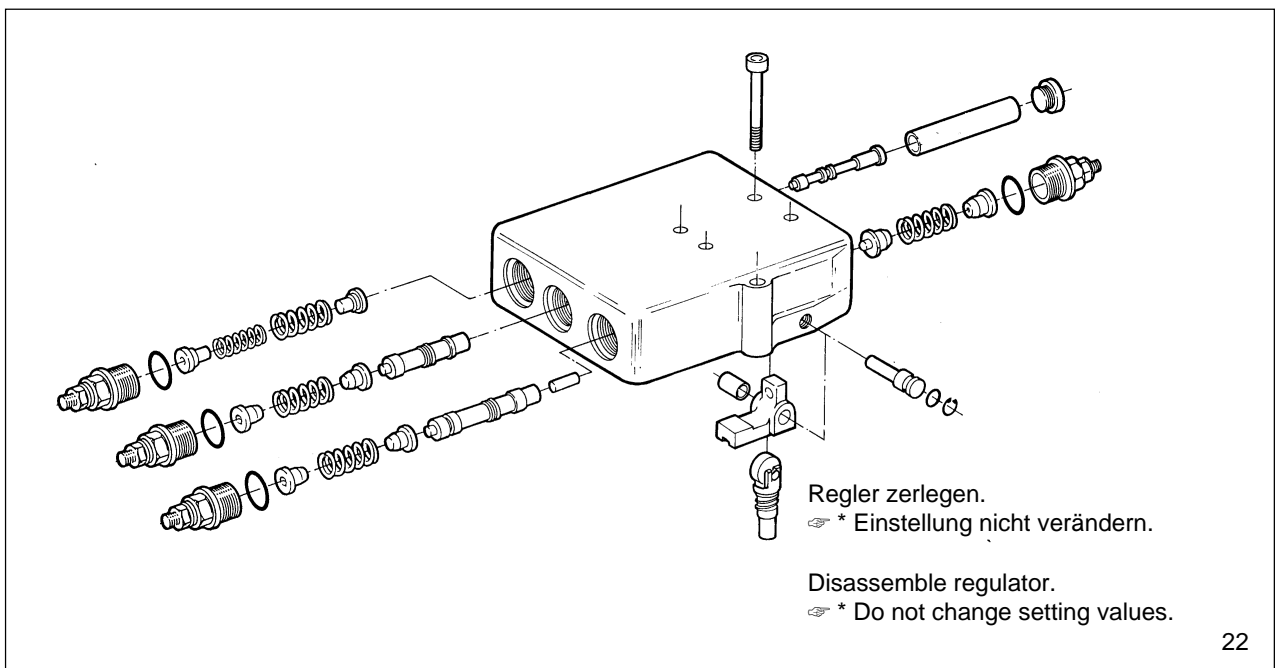

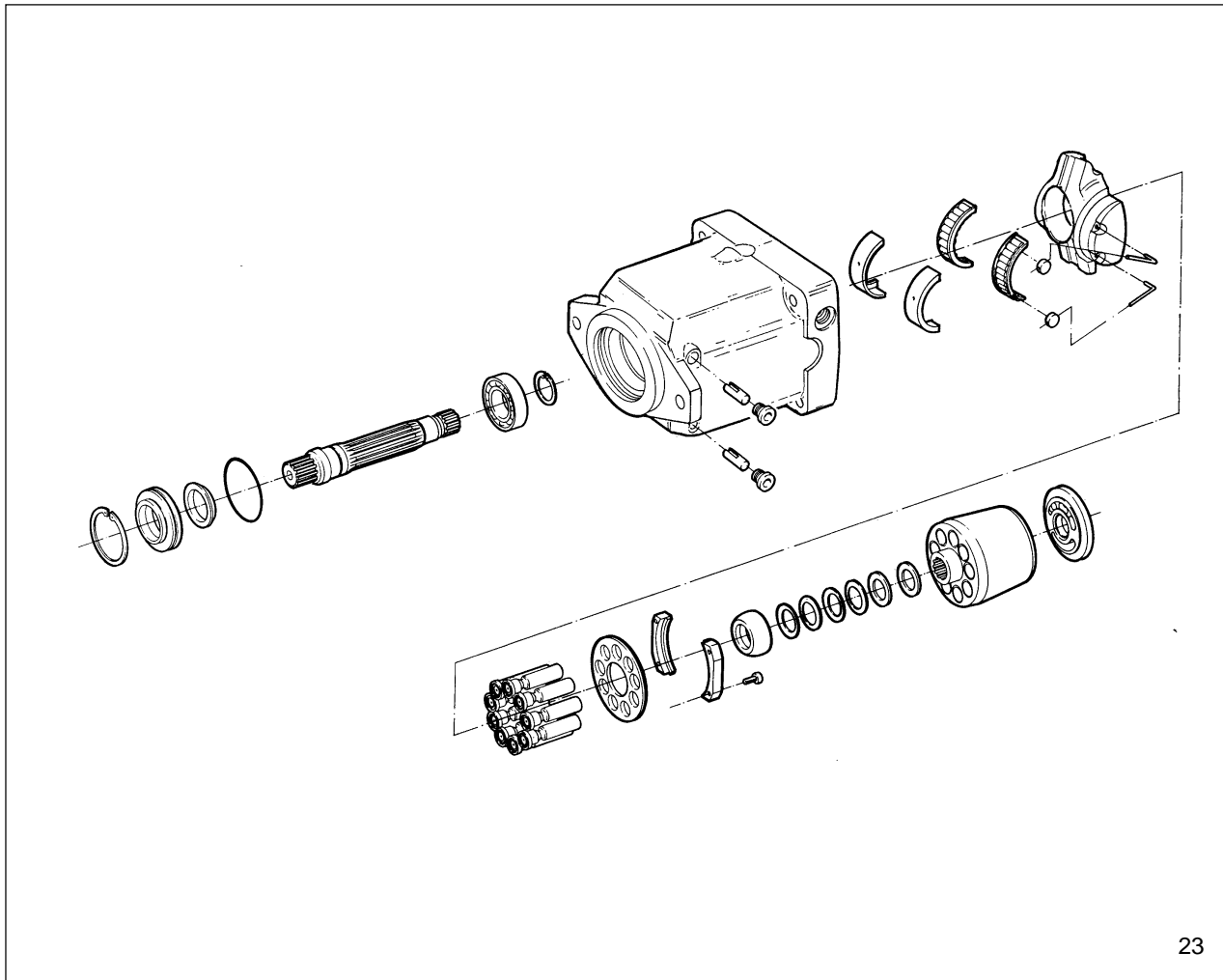

23

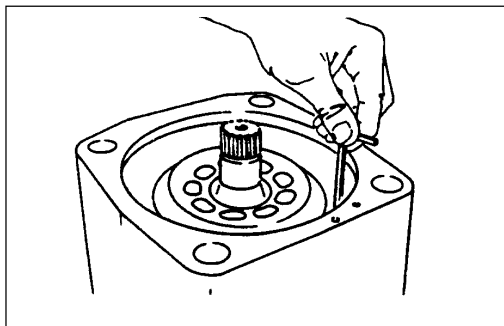

- 24 Haltesegment lösen.
Loosen fixing of the retaining segments.

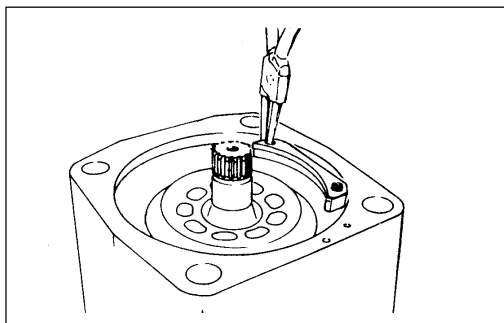

- 25 Haltesegment mit Schrauben ausbauen.
Remove retaining segments with screws.

Triebwerk ausbauen
Remove rotary group

Reparaturanleitung A11VO
Repair Instructions A11VO

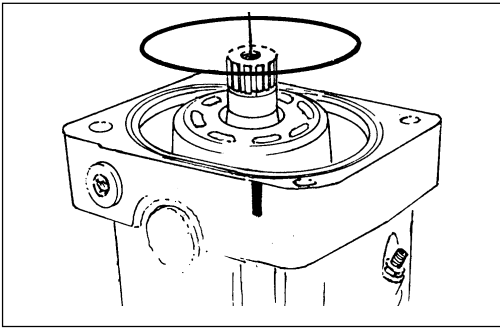

- 26 O-Ring ausbauen.
Remove O-ring.

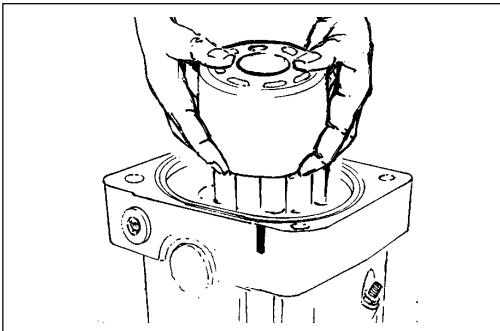

- 27 Zylinder mit Kolben ausbauen.
Remove cylinder with pistons.

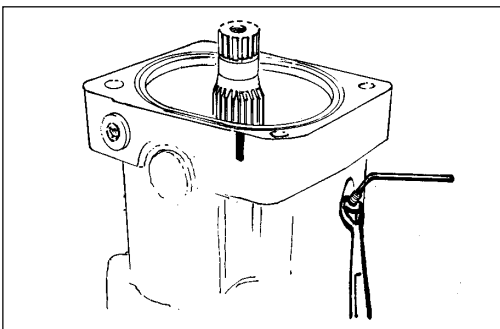

- 28 Q-min, Q-max- Einstellschrauben lösen.
Maß "X" festhalten.

Remove Q-min and Q-max screws after noting
down adjustment dimension.

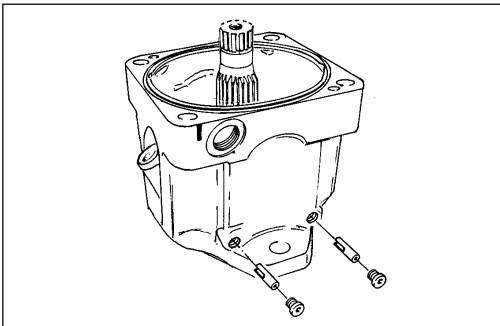

- 29 Gelenkstifte für Schwenklager ausbauen.
Remove joint pin for swivel cradle.



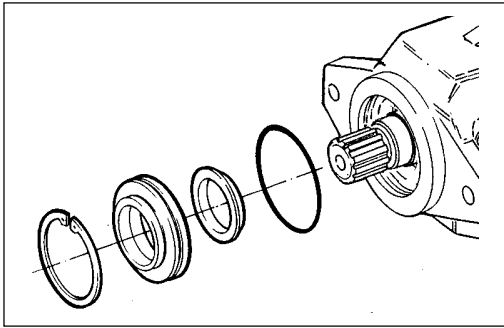

- 30 Verschlußring komplett ausbauen.
Remove completely cover ring.

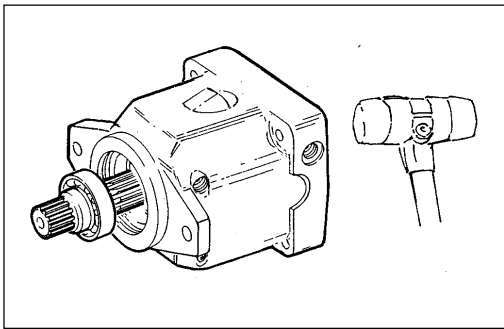

- 31 Triebwelle auspressen.
Press out drive shaft.

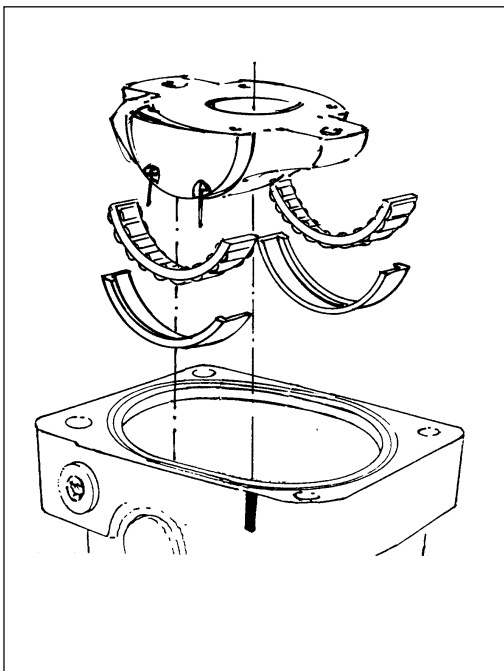

- 32 Schwenkwanne mit Lager und
Lagerschalen ausbauen.
Remove swivel cradle with bearing
as well as bearing case.

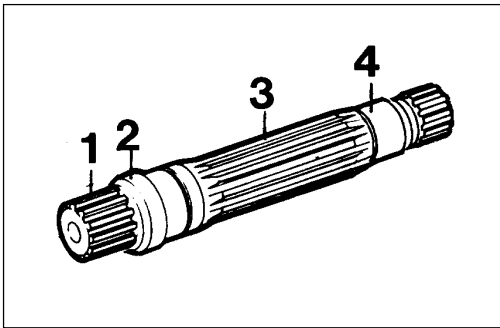

- 33 Kontrolle!
Verzahnung (1); Lauffläche WDR (2); Verzahnung (3);
Lagersitz (4).

Check!
Gears (1); Contact area shaft seal (2); Gears (3);
Bearing seat (4).

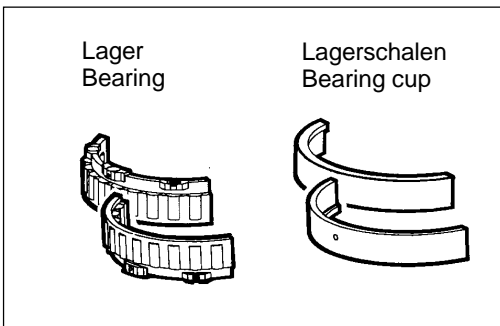

- 34 Kontrolle!
Käfig- Paar (1);
Lagerschalenpaar (2).

Check!
Cage set (1);
Bearing cup set (2).

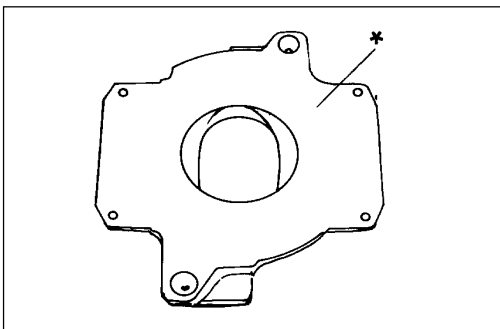

- 35 Kontrolle!
Gleitfläche (*).
- Check!
Contact area (*).

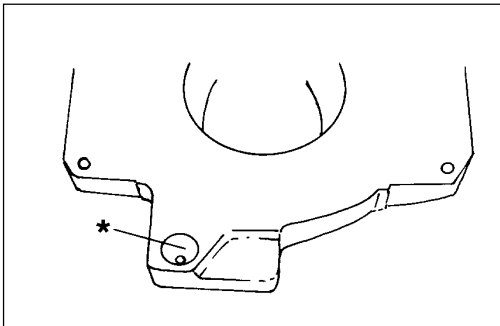

- 36 Kontrolle!
Kalotte für Regler (*).
- Check!
Socket for regulator (*).

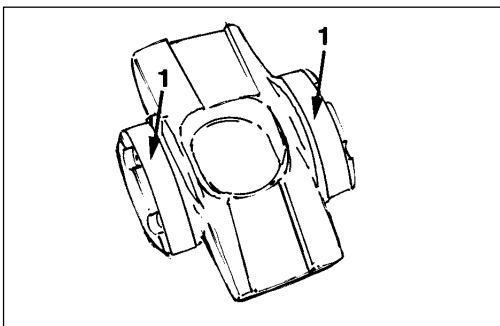

- 37 Kontrolle!
Lagerbahn (1).
- Check!
Contact area of bearing (1).

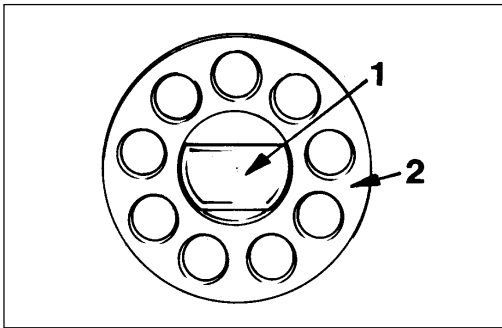

- 38 Kontrolle!
Rückzugkugel (1)
Rückzugplatte (2).

Inspection!
Retaining ball (1)
Retaining plate (2).

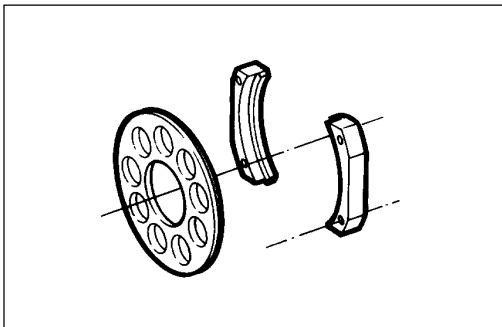

- 39 Kontrolle!
Haltesegmente

Inspection!
Fixing segments

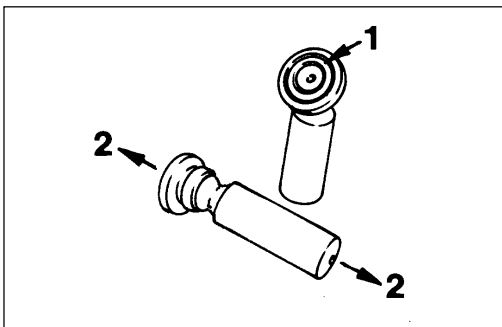

- 40 Kontrolle!
Gleitschuhe (1)
Axialspiel (2)

Inspection!
Slipper pads (1)
Axial backlash (2)

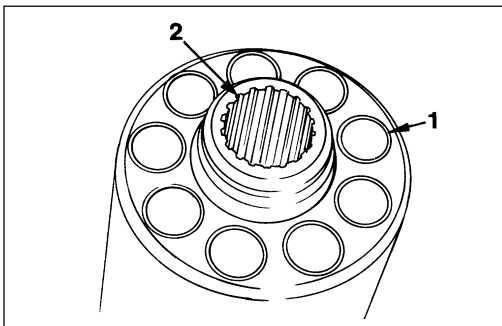

- 41 Kontrolle!
Zylinderbohrung (1)
Verzahnung (2)

Inspection!
Cylinder boring (1)
Gears (2)

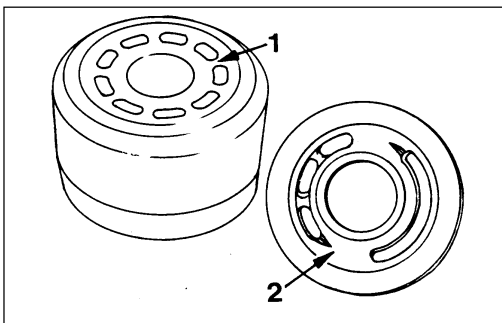

- 42 Kontrolle!
Zylindergleitfläche (1)
Gleitfläche Steuerplatte (2)

Inspection!
Cylinder contact area (1)
Contact area control plate (2)

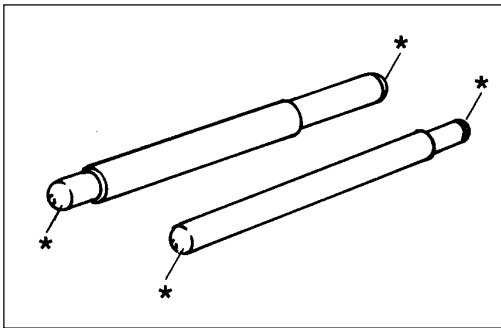

- 43 Kontrolle!
Kugelhöpfe (*)
- Check!
Fixing segments (*)

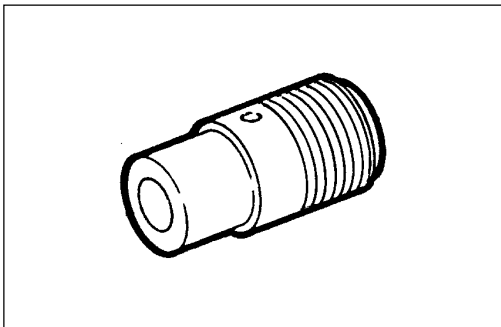

- 44 Kontrolle!
Kolben (*)
- Check!
Pistons (*)

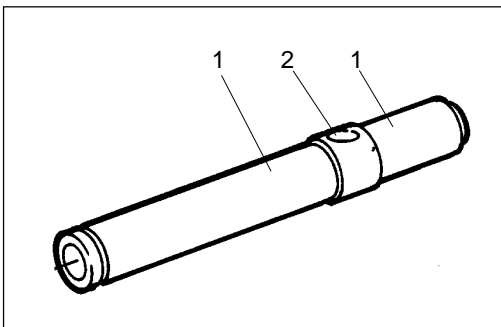

- 45 Kontrolle!
Stellkolben (1)
Bohrung - Steuerbüchse (2)
- Check!
Positioning piston (1)
Boring - control bush (2)

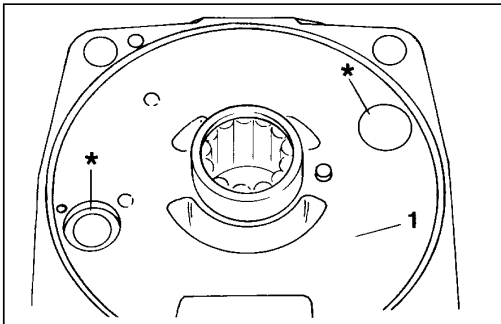

- 46 Kontrolle!
Bohrung (*)
Auflagefläche - Steuerplatte (1)
- Check!
Boring (*)
Contact area control plate (1)



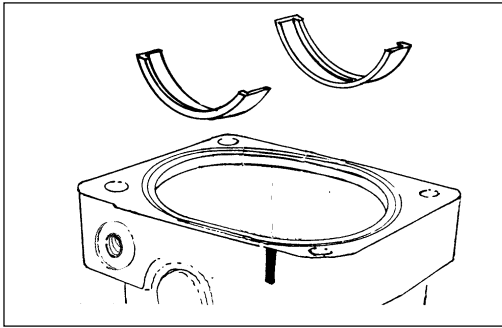

- 47 Lagerschalen einsetzen.
Insert bearing bell.

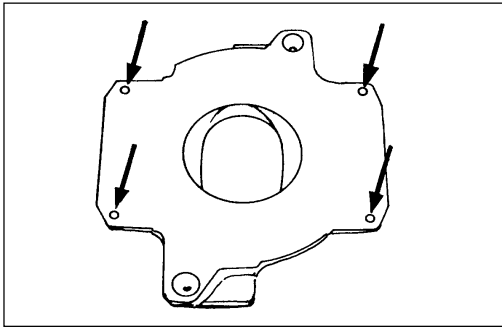

- 48 Gewindebohrungen reinigen.
Clean threaded borings.

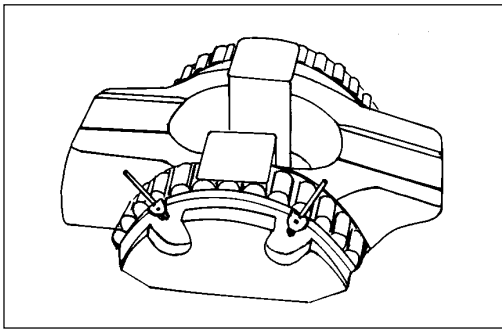

- 49 Lager mit Drahtführung auf Schwenkwiege montieren.
Mit Hilfsmittel festhalten.
Install bearings with wire guide on swivel cradle.
Fixing with auxiliary device.

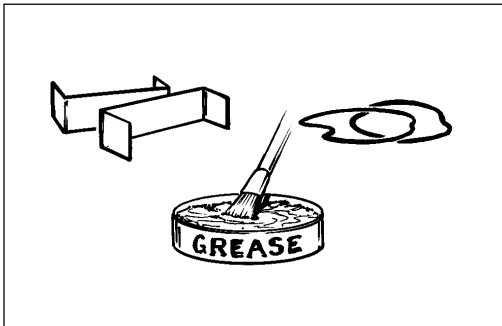

- 50 Hilfsmittel z.B.
- Klammer
- Gummiringe
- Fett
Auxiliary devices e.g.
Clamp
Rubber rings
Grease

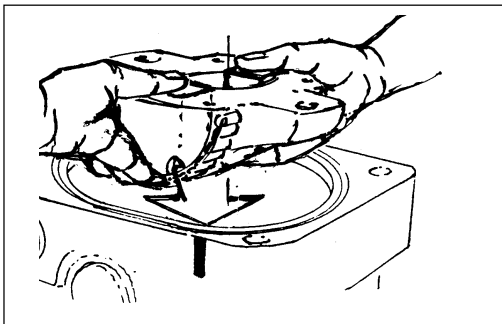

- 51 Schwenkwiege mit Lager in Lagerschalen einsetzen.
Achtung!
Einbaulage.
Place swivel cradle with bearing into bearing shell.
Attention!
Installation position.

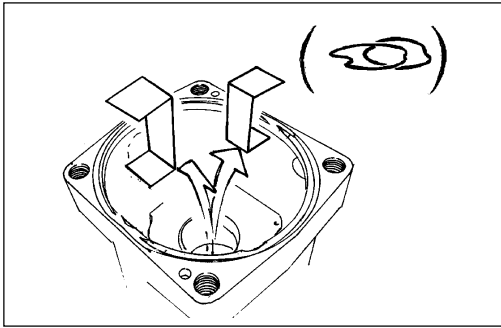

- 52 Hilfsmittel ausbauen.
Achtung! Lagersitzkontrolle.
- Remove auxiliary devices
Attention! Check bearing seats.

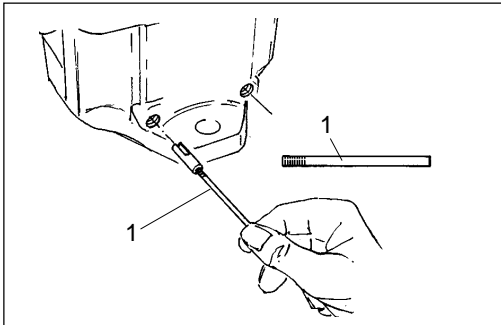

- 53 Führungsdraht ausrichten. Gelenkstifte einsetzen.
Verschlußschrauben einbauen.
1. Hilfsmittel (Gewindestange)
- Adjust guide wire. Install joint pins.
Install locking screws.
1. Auxiliary device (threaded rod)

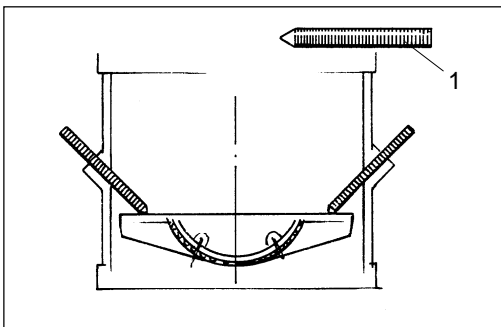

- 54 Schwenkwaage mit Gewindestift in Nulllage fixieren.
1. Hilfsmittel (Gewindestift 2x)
- Fit swivel cradle with threaded pin in zero position.
1. Auxiliary device (threaded pins 2x)

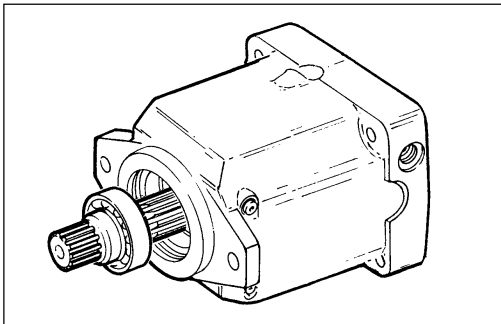

- 55 Triebwelle einsetzen.
- Install drive shaft.

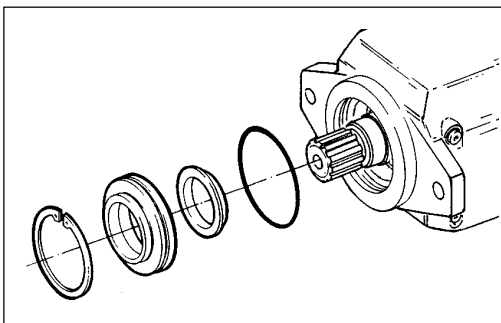

- 56 Verschlußring montieren.
- Mount cover ring.

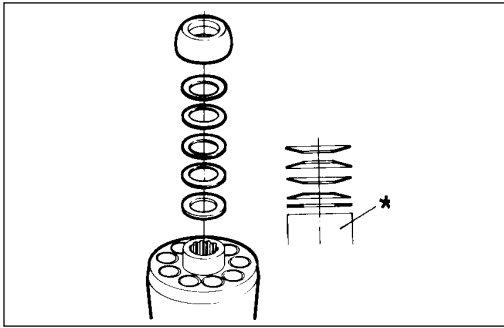

- 57 Abstimmscheibe, Federn und Rückzugkugel montieren.
Hinweis: Richtige Einbaulage beachten *.

Mount shims, springs and retaining ball.
Note: Observe correct mounting position *.

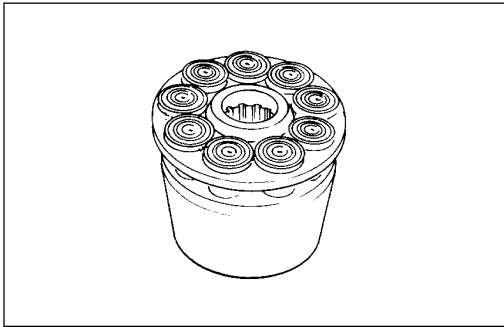

- 58 Rückzugeinrichtung mit Kolben in Zylinder montieren.

Place retaining plate with piston into cylinder.

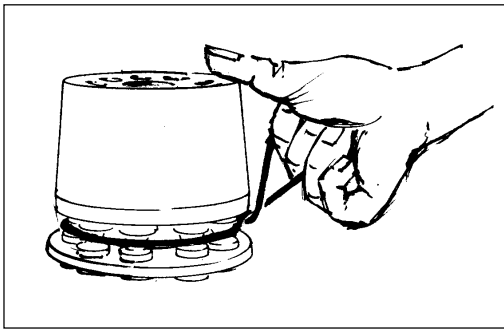

- 59 Montagehilfe:
Mit O-Ring Kolben festhalten.

Assembly hint:
Fix pistons with the aid of an O-ring.

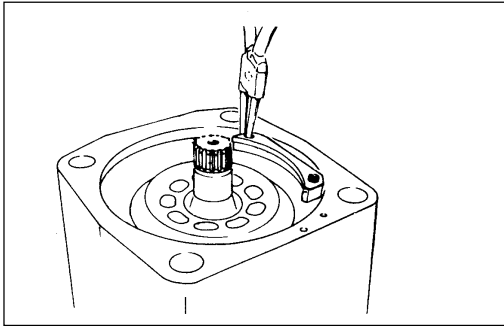

- 60 Haltesegmente einsetzen.

Insert fixing segments.

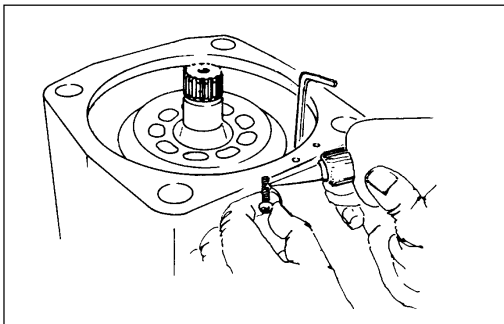

- 61 Schrauben mit Loctite einsetzen.
Achtung!
Aushärtezeit Loctite beachten - wichtig!
Schrauben nach Drehmoment anziehen.

Install screws with Loctite.
Attention!
Pay attention with hardening time - important!
Tight screws with torque value.

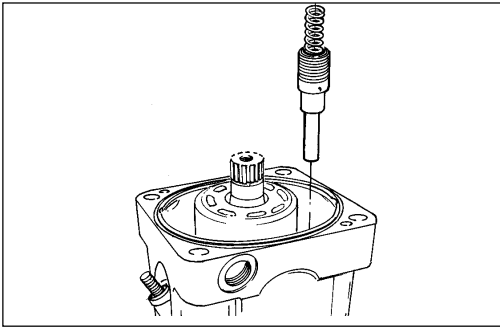

- 63 Hydraulische Verstellung - groß.
Hydraulic control rod - big size.

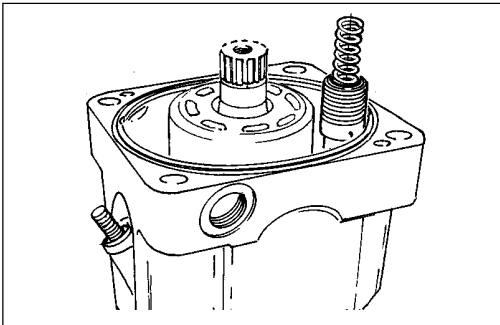

64

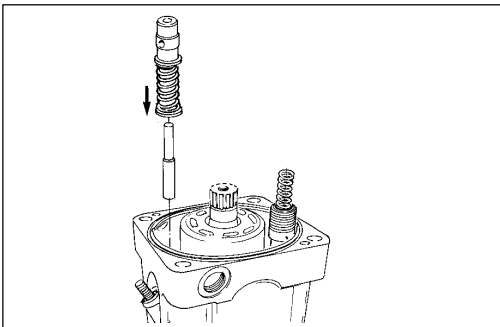

- 65 Hydraulische Verstellung - klein.
Hydraulic control rod - small size.

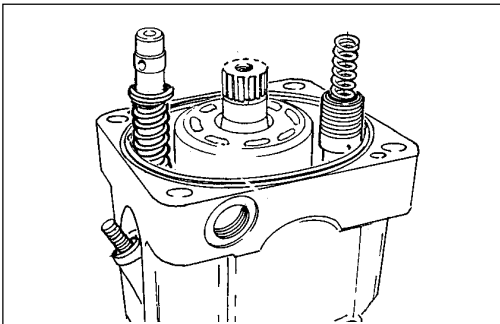

66

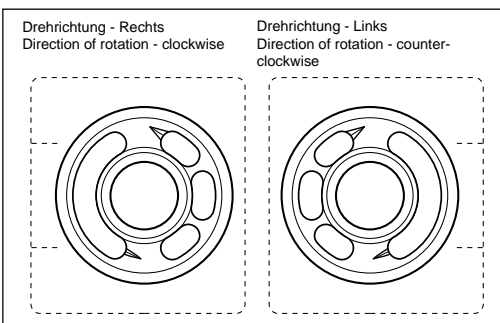

- 67 Steuerplatte einsetzen.
Achtung!
Einbaulage (Drehrichtung).
- Install control plate.
Attention!
Installation position (Direction of rotation).

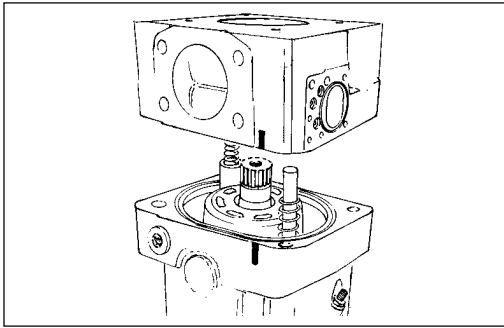

67

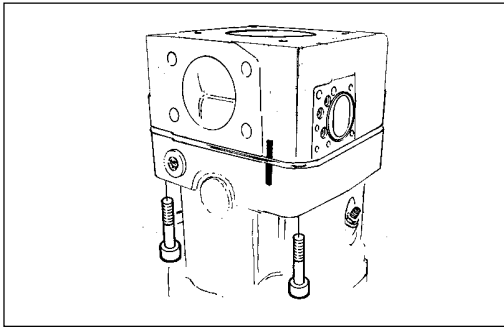

68

Anschlußplatte anbauen und mit Schrauben befestigen.
Achtung!
Drehmoment - Schrauben.

Fix port plate, assembly with screws.
Attention!
Torque - screws

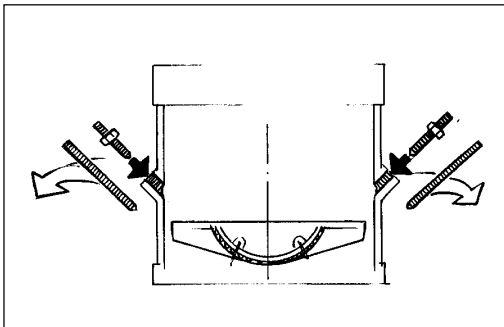

69

Gewindestift ausbauen.
Q-min, Q-max- Schrauben einbauen.
Achtung!
Einstellmaß

Remove threaded pins.
Install Q-min, Q-max- screws.
Adjustment measure

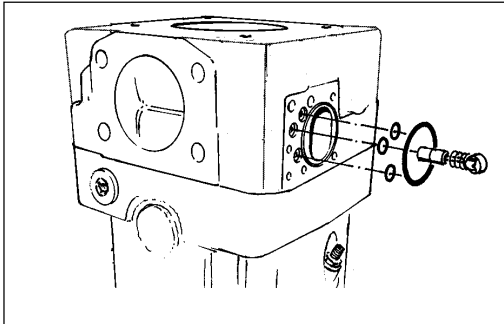

70

Meßkolben mit O-Ringen einbauen.
Install measuring piston with O-rings.

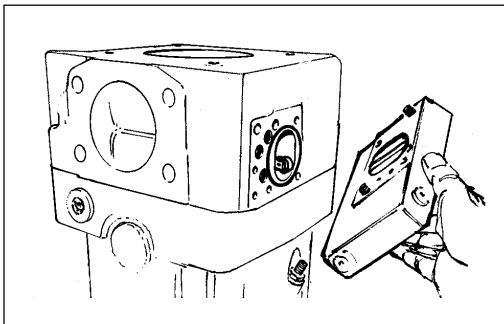

71

Regler anbauen.
Place regulator.

Anziehdrehmomente Tightening torques

Reparaturanleitung A11VO Repair Instructions A11VO

Anziehdrehmomente für Schaftschrauben (Metrisches ISO-Regelgewinde)				
Die nebenstehenden Werte für Anziehdrehmomente gelten nur für Schaftschrauben mit metrischem ISO-Regelgewinde und Kopfauflagemaßen nach DIN 912, DIN 931 und DIN 933. Außerdem gelten diese Werte nur für leicht oder nicht geölte, unbehandelte Oberflächen, sowie nur bei Verwendung von Drehmoment- und Kraftbezugungsschlüsseln.	Gewindegröße	Festigkeitsklassen		
		8.8	10.9	12.9
		Anziehdrehmoment(Nm)		
M 3	1,1	1,6	1,9	
M 4	2,9	4,1	4,9	
M 5	6	8,5	10	
M 6	10	14	17	
M 8	25	96	41	
M10	49	69	83	
M12	86	120	145	
M14	135	190	230	
M16	210	295	355	
M18	290	405	485	
M 20	410	580	690	
M 22	550	780	930	
M 24	710	1000	1200	
M 27	1050	1500	1800	
M 30	1450	2000	2400	

Tightening torques for shaft bolts (Metric ISO Standard Thread)				
The values for tightening torques shown in the table are valid only for shaft bolts with metric ISO- standard threads and head support surface dimensions in accordance with DIN 912, DIN 931 and DIN 933. These values are also valid only for light or unoled, untreated surface as well as for use only with torque-indicating wrenches and force limiting tools.	Thread size	Strength Classes		
		8.8	10.9	12.9
		Tightening Torque (lb.ft)		
M 3	0,8	1,2	1,4	
M 4	2,1	3,0	3,6	
M 5	4,4	6,3	7,4	
M 6	7,4	10,3	12,5	
M 8	18,4	25,8	30,2	
M10	36,1	50,9	61,2	
M12	63,4	88,4	106,9	
M14	99,5	140,0	169,5	
M16	154,8	217,4	261,6	
M18	213,7	298,5	357,4	
M 20	302,2	427,5	508,5	
M 22	405,4	574,9	685,4	
M 24	523,5	737,0	884,4	
M 27	773,9	1105,5	1326,6	
M 30	1068,7	1474,0	1768,8	

Anziehdrehmomente für Verschlusschrauben VSTI (Metrisches Feingewinde)			
Gewindegröße	Bezeichnung	Anziehdrehmoment(Nm)	
M 8 x 1	VSTI 8 x 1 -ED/SA	= 5	
M 10 x 1	VSTI 10 x1 -ED	= 10	
M 12 x 1,5	VSTI 12 x 1,5 -ED	= 20	
M 14 x 1,5	VSTI 14 x 1,5 -ED	= 30	
M 16 x 1,5	VSTI 16 x 1,5 -ED/SA	= 30	
M 18 x 1,5	VSTI 18 x 1,5 -ED/SA	= 40	
M 20 x 1,5	VSTI 20 x 1,5 -ED/SA	= 50	
M 22 x 1,5	VSTI 22 x 1,5 -ED	= 60	
M 26 x 1,5	VSTI 16 x 1,5 -ED/SA	= 70	
M 27 x 2	VSTI 27 x 2 -ED	= 90	
M 30 x 1,5	VSTI 30 x 1,5 -ED/SA	= 100	
M 33 x 2	VSTI 33 x 2 -ED/SA	= 120	
M 42 x 2	VSTI 42 x 2 -ED/SA	= 200	
M 48 x 2	VSTI 48 x 2 -ED	= 300	

Tightening torques for locking screws VSTI (Metric ISO fine thread)			
Thread size	Designation	Tightening torques (lb.ft)	
M 8 x 1	VSTI 8 x 1 -ED/SA	= 4	
M 10 x 1	VSTI 10 x1 -ED	= 7	
M 12 x 1,5	VSTI 12 x 1,5 -ED	= 15	
M 14 x 1,5	VSTI 14 x 1,5 -ED	= 22	
M 16 x 1,5	VSTI 16 x 1,5 -ED/SA	= 22	
M 18 x 1,5	VSTI 18 x 1,5 -ED/SA	= 29	
M 20 x 1,5	VSTI 20 x 1,5 -ED/SA	= 37	
M 22 x 1,5	VSTI 22 x 1,5 -ED	= 44	
M 26 x 1,5	VSTI 16 x 1,5 -ED/SA	= 51	
M 27 x 2	VSTI 27 x 2 -ED	= 66	
M 30 x 1,5	VSTI 30 x 1,5 -ED/SA	= 74	
M 33 x 2	VSTI 33 x 2 -ED/SA	= 88	
M 42 x 2	VSTI 42 x 2 -ED/SA	= 147	
M 48 x 2	VSTI 48 x 2 -ED	= 220	

Anziehdrehmomente für Seal-Lock Bundmuttern (Metrisches ISO-Regelgewinde)				
Die nebenstehenden Werte für Anziehdrehmomente gelten nur für Seal-Lock Bundmuttern der Festigkeitsklasse 8.8 mit metrischem ISO-Regelgewinde.	Gewindegröße	Festigkeitsklassen		
		8.8	10.9	12.9
		Anziehdrehmoment (Nm)		
M 6	10	/	/	
M 8	22	/	/	
M 10	40	/	/	
M 12	69	/	/	
M 14	110	/	/	
M 16	170	/	/	

Tightening torques for seal-lock nuts (Metric ISO-Standard Thread)				
The values for tightening torques shown in the table are valid only for seal-lock nuts of the strength class 8.8 and with metric ISO-standard thread.	Thread size	Strength classes		
		8.8	10.9	12.9
		Tightening torque (lb.ft)		
M 6	7,4	/	/	
M 8	16,2	/	/	
M 10	29,5	/	/	
M 12	50,9	/	/	
M 14	81,1	/	/	
M 16	125,3	/	/	

Anziehdrehmomente für Linsenschrauben mit Kreuzschlitz DIN 7985 (Metrisches ISO-Regelgewinde)				
Die nebenstehenden Werte für Anziehdrehmomente gelten nur für Linsenschrauben mit Kreuzschlitz DIN 7985 der Festigkeitsklasse 8.8 mit metrischem ISO-Regelgewinde	Gewindegröße	Festigkeitsklassen		
		8.8	10.9	12.9
		Anziehdrehmoment(Nm)		
M 3	1,1	/	/	
M 4	2,9	/	/	
M 5	6	/	/	
M 6	10	/	/	
M 8	25	/	/	
M10	49	/	/	

Tightening torques for cross-slotted lens head screws DIN 7985 (Metric ISO- Standard Thread)				
The values for tightening torques shown in the table are valid only for cross-slotted lens head screws DIN 7985 of the strength class 8.8 and with metric ISO-standard thread.	Thread size	Strength classes		
		8.8	10.9	12.9
		Tightening torques (lb.ft)		
M 3	0,8	/	/	
M 4	2,1	/	/	
M 5	4,4	/	/	
M 6	7,4	/	/	
M 8	18,4	/	/	
M10	36,1	/	/	

