

Spare parts list

Product Unit

Axial Piston Units

Part No.: R910915383

Designation: A A2F M 250 /60W-VZB010

Drawing no.: R910904790

Pos.	Part No.	Designation	Quantity	
1	R910993321	TW A2F M 250 /60W-VZ	1 ST	L
4	R902438405	PUMP HOUSING	1 ST	
5	R910801176	PORT PLATE	1 ST	
8	R910186988	O-RING	1 ST	D
10	R910126411	ZYL.SCHR.M 16X 50 -10.9 DIN 912 #310NM	8 ST	
11	R910740667	CYLINDER PIN	2 ST	
12	R910647187	V-SCHRAUBE N 02.009-M 22X1,5 V # 60NM	1 ST	D
13	R910532347	V-SCHRAUBE N 02.009-M 14X1,5 V # 30NM	1 ST	D

Safety Notes:

Service – and repair works have to be carried out by the Bosch Rexroth AG or their repair stations only. We do not grant any warranty for defects due to assembly, maintenance or repair not effected by the Bosch Rexroth AG or their repair stations.

L = Assembly group D = Sealing element

Page: 1

Date: 31.05.2006

Status of version: 3/2006

Brueninghaus Hydromatik GmbH, Werk Horb, An den Kelterwiesen 14, D-72160 Horb

<https://www.maragon-parts.com/>

Spare parts list

Product Unit
Axial Piston Units

Part No.: R910915383
Designation: A A2F M 250 /60W-VZB010

Drawing no.: R910904790

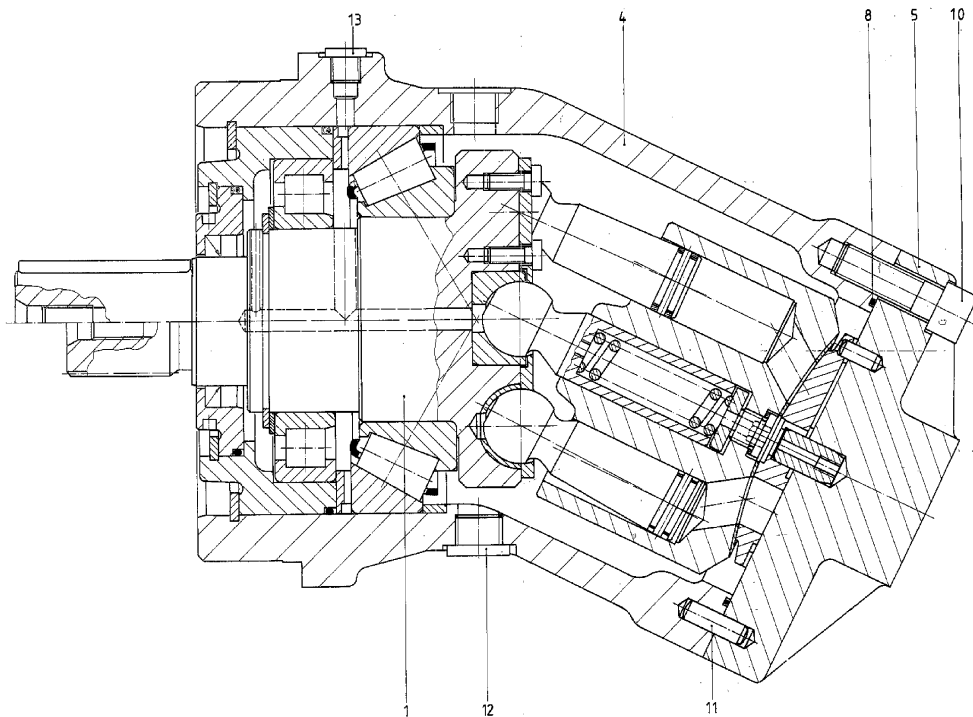

L = Assembly group D = Sealing element

Status of version: 3/2006

Page: 2

Date: 31.05.2006

Spare parts list

Product Unit
Axial Piston Units

Part No.: R910993321
Designation: TW A2F M 250 /60W-VZ

Drawing no.: R910913385

Pos.	Part No.	Designation	Quantity	
1	R902407113	DRIVE FLANGE	1 ST	
3	R910798754	PISTON	7 ST	
4	R910798789	PISTON RING	14 ST	
6	R902432783	ZYLINDER BG32/BR6	1 ST	
7	R910978915	CONTROL PLATE	1 ST	
8	R910900130	PRESSURE PIN	1 ST	
9	R910709042	RETAINING PLATE	1 ST	
10	R910904785	BEARING RING	1 ST	
11	R902412282	SEAL FLANGE	1 ST	
12	R910788589	CENTERING BOLT	1 ST	
13	R910969915	ADJUSTMENT RING	1 ST	
14	R910900002	SPRING	1 ST	
15	R910900003	SHIM	1 ST	
16	R910999169	ABSTIMMSATZ TW-LAG. BG32/BR6	1 ST	
17	R910969893	SPACER BOLT	1 ST	
21	R910904776	TAPERED-ROLLER BEARING	1 ST	
22	R910693944	PLAIN ROLLER BEARING	1 ST	
24	R910963544	WDR BAFSL1SF 60X 80X 7/5.5 -FPM 75 V 595	1 ST	D
25	R910113689	O-RING	1 ST	D
26	R910928968	O-RING	1 ST	D
28	R910106151	RETAINING RING	1 ST	
29	R910797448	SICHERUNGSR. 125X4,0	DIN 472	1 ST
30	R910188034	SICHERUNGSR. 85X3,0	DIN 471	1 ST
32	R910575038	CYLINDER PIN	1 ST	
34	R910203297	SHIM	1 ST	
39	R910584614	ZYL.SCHR.M 8X 16 -10.9 DIN 912 #37NM	14 ST	

Spare parts list

Product Unit
Axial Piston Units

Part No.: R910993321
Designation: TW A2F M 250 /60W-VZ

Drawing no.: R910913385

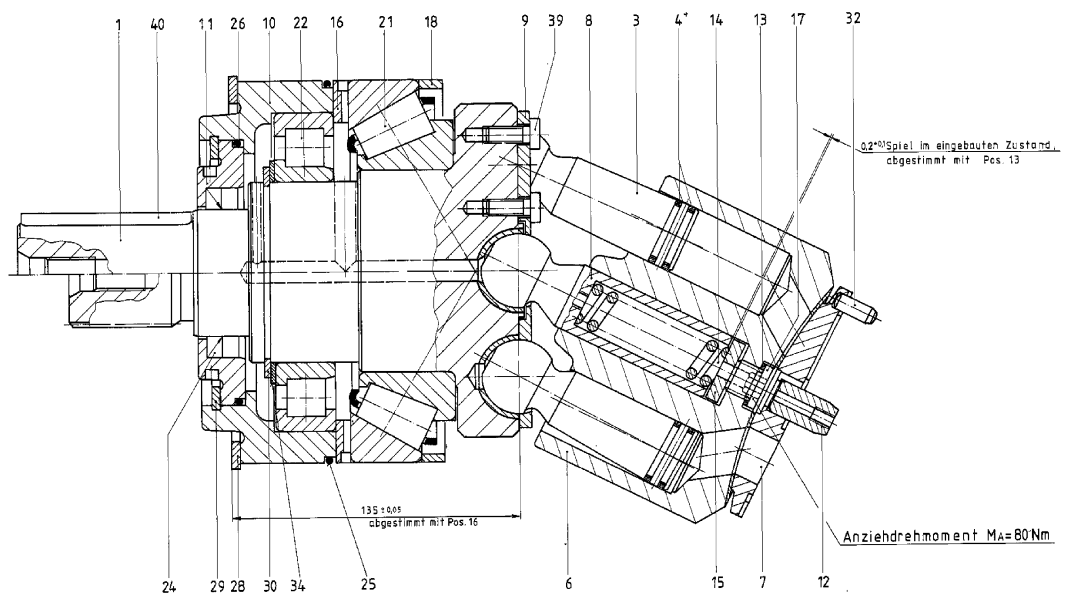

+ Die Kennzeichnung an den Kolbenringen zeigt zum Kolbenboden hin

Gewinde mit Loctite
Nr. 242 gesichert