

Hydraulic-Training Axial Piston Units

Basic Principles
RE 90600/01.98

Axial Piston Units

Page



1 Basic Principles

1.1 Types of Hydraulic Circuit

2-3

1.1.1 Open circuit

1.1.2 Closed Circuit

2 Principles of Function

2.1 Bent-Axis

4-9

2.1.1 Bent-Axis Principle

2.1.2 Description of Function

2.1.3 Principles of Calculation

2.1.4 Rotary Group Forces

2.1.5 40°-Tapered Piston,
Bent-Axis

Rotary Group

2.1.6 Examples of Types

2.1.7 Symbols

2.2 Swashplate

10-15

2.2.1 Swashplate Principle

2.2.2 Description of Function

2.2.3 Principles of Calculation

2.2.4 Rotary Group Forces

2.2.5 Swashplate Rotary Group

2.2.6 Examples of Types

2.2.7 Symbols

3 Components

16-28

A Selection of Typical
Models from the
individual Product Groups

3.1 Standard Models

to of Bent-Axis and

3.10 Swashplate Design

3.11 Summary of Control Devices

1 Basic Principles

1.1 Types of Hydraulic Circuit

For the hydraulic engineer, there are three basic types of circuit to consider:

- open circuit
- closed circuit
- semi-closed circuit

In the following we look at open and closed circuits in some details. The semi-closed circuit is a mixture of these two types of circuit and is used in applications where volume compensation via prefill valves is necessary (e.g. when using a single rod cylinder).

1.1.1 Open Circuit

Open circuit normally means the case where the pump suction line leads below a fluid level whose surface is **open** to atmospheric pressure. Maintenance of a pressure balance between the air in the hydraulic tank and the air in the atmosphere guarantees good *pump suction characteristics*. There must be no resistance in the inlet line which might cause pressure to drop below the so-called *suction head/suction limit*.

Axial piston units are *self-priming*; in certain special cases, however, a low pressure is applied to the suction side.

In **open** circuit hydraulic fluid is fed to the user via directional control valves and returned to the tank in the same way.

Typical features of the **open** circuit are:

- suction lines - short length, large diameter
 - directional control valves - flow-related sizes
 - filter / cooler - flow-related sizes
 - tank size - a multiple of the max. pump flow in litres
 - pump arrangement - adjacent to or below the tank
-
- drive speeds - limited by the suction head
 - load maintained in return by valves

The **open** circuit is standard in many industrial and mobile applications - from machine tools, through

Open Circuit

The Way to the complete Hydraulic System:
(explanation of symbols, see page 3)

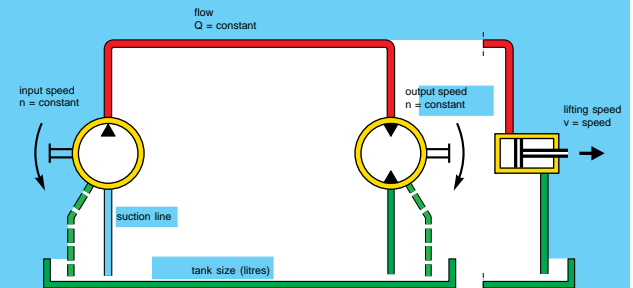

Basic system with hydraulic pump and hydraulic motor (or cylinder). **Single** direction of input, output and lift.

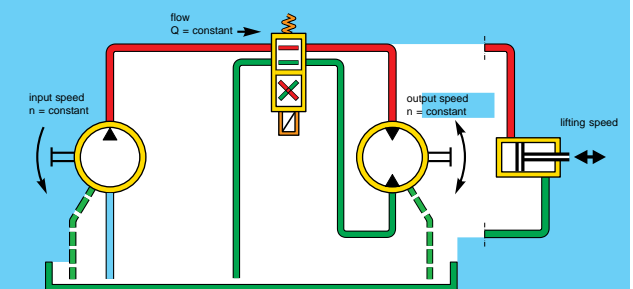

The directional control valve allows **reversal** of the direction of rotation or of movement at the user.

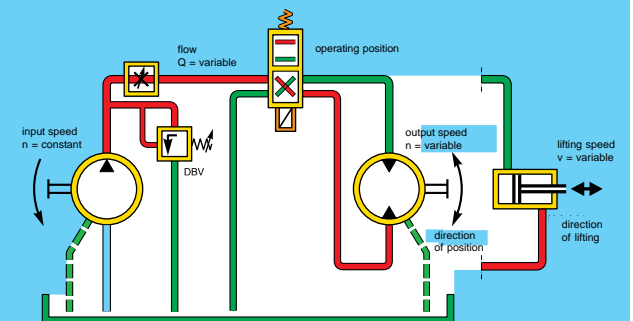

Variable output speed is achieved by installation of a flow controller for variable flow. The pressure relief valve (DBV) protects the system from overload.

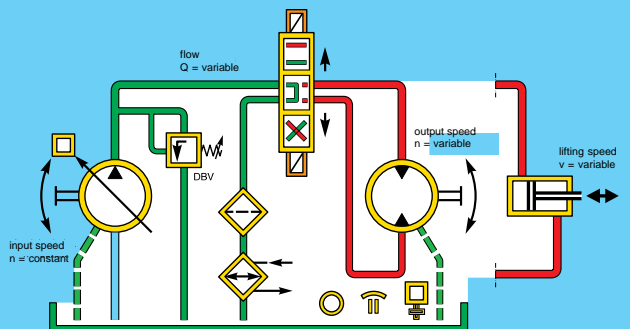

Here, the fixed pump and flow controller have been replaced by a variable pump. Further valve functions have been added, e.g. free-wheeling of the user. Filter, cooler and other accessories are also fitted.

1.1.2 Closed Circuit

A hydraulic system is described as **closed** when the hydraulic fluid is returned from the user direct to the pump.

There is a high pressure and a low pressure side, depending on the direction of load (take-off torque at the user).

The high pressure side is protected by pressure relief valves which unload to the low pressure side. The hydraulic fluid remains in the circuit.

Only the continuous leakage from pump and motor (dependent on operating data) must be replaced.

This fluid is normally replenished by an auxiliary pump flanged direct onto the main pump which delivers a continuous, adequate supply of fluid (boost fluid) from a small tank via a check valve into the low pressure side of the **closed** circuit. Any surplus flow of the boost pump, which operates in *open* circuit, is returned via a boost-pressure relief valve to the tank. The boosting of the low pressure side enhances the pump-operating characteristics.

Typical features of the **closed** circuit for axial piston units are:

- directional control valves - small sizes for pilot operation
- filter/cooler - small sizes
- tank size - small, dimensioned to suit boost pump flow and volume of system
- speed - high limiting values through boost
- arrangement/mounting - position-flexible/optional
- drive - completely reversible through centre position
- load maintained - via the drive motor
- feedback of braking power

Explanation of Symbols / Colour Code for Open and Closed Circuits

- red — (high) pressure line
- blue — (low, boost) pressure line
- blue — suction line
- green — return line (tank, bypass pressure)
- green — leakage line
- yellow □ hydraulic components (pump, motor cylinder, valves, accessories)
- orange □ control element (solenoids, springs)

Closed Circuit A Step-by-Step Guide (explanation of symbols, see below left)

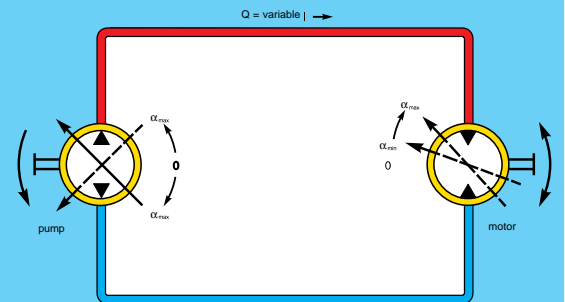

Basic system with variable pump and variable motor. **Single** pump input drive direction. Motor power take-off in **both** directions. The pump can be swivelled smoothly over centre, i.e. the direction of flow is reversible.

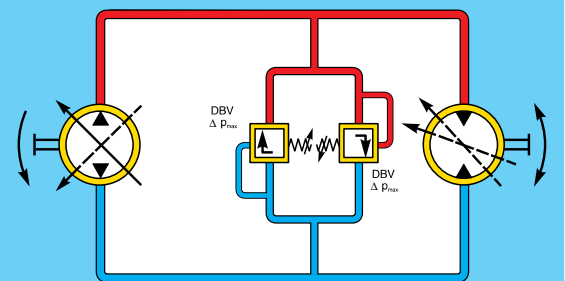

Pressure relief valves, one each for the high and low pressure sides, prevent the maximum permissible pressure from being exceeded.

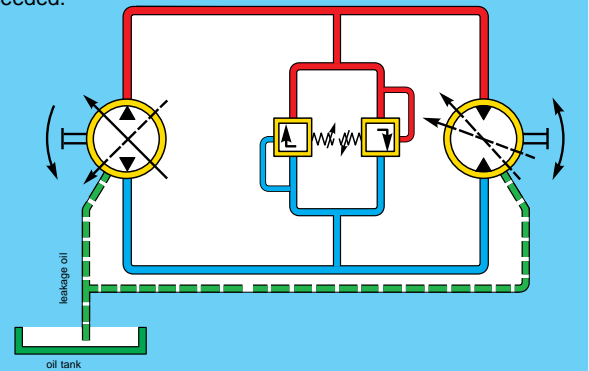

The leakage from pump and motor is led back to a small tank and must be replenished!

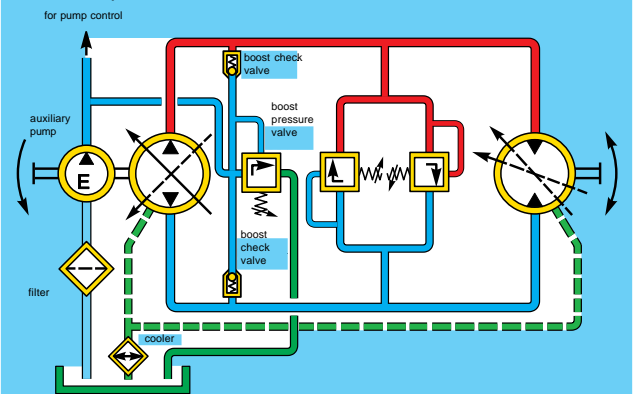

An auxiliary pump for replenishment of leakage oil and control of the pump. Boost check valve RV. Boost pressure relief valve DBV. Fitted filter, cooler and accessories.

2 Principles of Function

2.1 Bent Axis



Example:

Fixed Displacement Unit
with tapered piston rotary group

Schematic Diagram of a Bent-Axis Unit
with fixed or variable swivel angle α

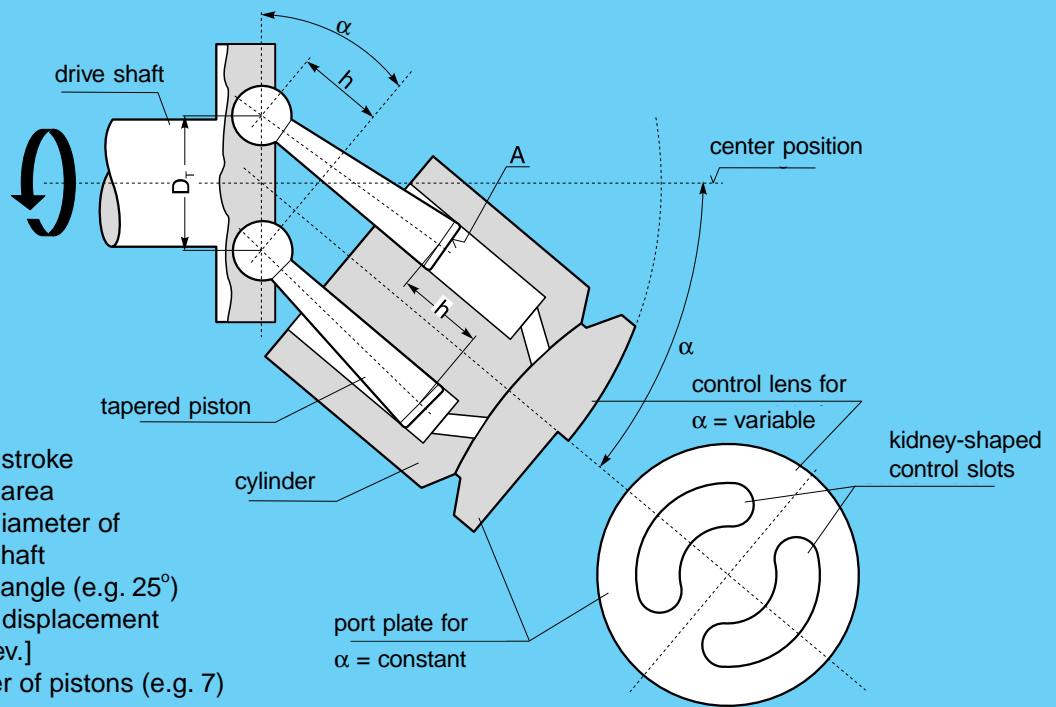

- h = piston stroke
- A = piston area
- D_T = pitch diameter of drive shaft
- α = swivel angle (e.g. 25°)
- V_g = geom. displacement [$\text{cm}^3/\text{rev.}$]
- x = number of pistons (e.g. 7)
- $h = D_T \cdot \sin \alpha$
- $V_g = x \cdot A \cdot h$
- $V_g = x \cdot A \cdot D_T \cdot \sin \alpha$

2.1.1 Bent-Axis Principle

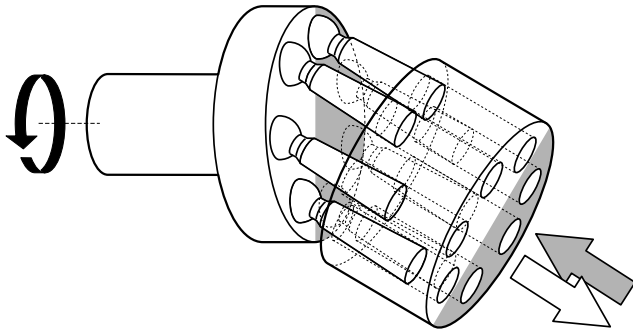

The bent-axis rotary group is a displacement unit whose displacement pistons are arranged at an angle to the drive shaft.

Pump Function:

Through the flexible piston/piston rod arrangement,

rotation of the drive shaft also causes the cylinder to rotate without the need for a Cardan coupling. The pistons execute a stroke within the cylinder bores dependent on the angle of inclination of the *bent axis*. The hydraulic medium is fed to the low pressure (inlet) side of the pump and pumped out by the pistons on the high pressure (outlet) side into the system.

Motor Function:

In motor operation, the process is reversed and pressure oil is fed to the inlet side of the unit. The pistons perform a stroke which is converted via the flexible piston mounting on the drive flange into a rotary movement. The cylinder rotates with the pistons, generating an output torque on the drive shaft. Oil exiting on the outlet side flows back into the system.

Swivel Angle:

The tilt/swivel angle of the fixed displacement unit is determined by the housing and is therefore fixed. On a variable unit, this angle is infinitely variable within specific limits. Changing the swivel angle changes the piston stroke, thus allowing variable displacement.

2.1.2 Description of Function Example: Fixed Displacement Unit

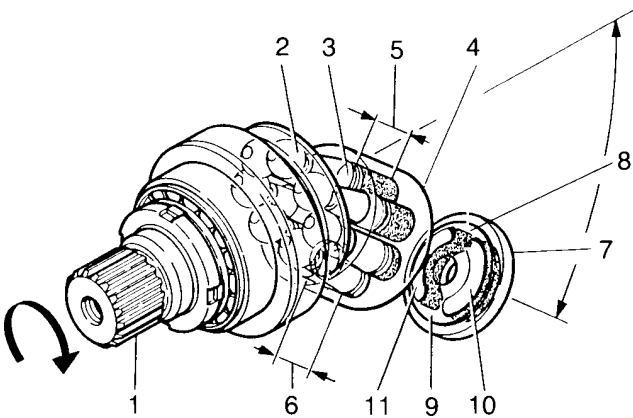

- | | |
|---------------------|-----------------------------------|
| 1 = drive shaft | 7 = port plate |
| 2 = piston | 8 = upper dead point OT |
| 3 = piston area | 9 = lower dead point UT |
| 4 = cylinder | 10 = control slot, pressure side |
| 5 = pressure stroke | (for direction of rotation shown) |
| 6 = suction stroke | 11 = control slot, suction side |
| | (for direction of rotation shown) |

Description

The axial piston units of bent-axis design with fixed or variable displacement can operate as hydraulic pumps or hydraulic motors.

When used as a pump, the flow is proportional to the input speed and the swivel angle. If the unit is used as a motor, the output speed is proportional to the flow through the unit. The input (pump) or output (motor) torque increases with the pressure drop between the high and low pressure sides. In pump operation, mechanical energy is converted into hydrostatic power, while in motor operation, inversely, hydrostatic power is converted into mechanical energy. By adjusting the swivel angle of a variable pump or motor it is possible to vary the displacement and thus the flow.

Function

... as a pump in open circuit:

On rotation of the drive shaft, the cylinder is caused to rotate by seven pistons flexibly mounted in a circular arrangement on the drive shaft. The cylinder slides on the spherical port plate which has two kidney-shaped control slots. As the cylinder rotates, each of the seven pistons moves from the upper dead point OT to the lower dead point UT and back, thereby executing a stroke dependent on the swivel angle. The piston movement from the lower to the upper dead point in the cylinder bore produces the suction stroke, whereby a quantity of oil relative to the piston area and piston stroke is sucked in through the control slot on the suction side.

On further rotation of the drive shaft, as the pistons move from the upper to the lower dead point, oil is pushed out through the other control slot (pressure side). The pistons are held against the drive shaft by hydraulic pressure.

... as a motor:

The motor function is the reverse of the pump function. In this case, hydraulic oil is fed via the connection plate through a control slot to the cylinder bores. 3 or 4 cylinder bores are located over the pressure side control slot, 4 or 3 over the return-line side, with one bore possibly being covered by part of the port plate directly at the dead point. The force generated as a product of pressure and piston area acts on the drive shaft to produce the output torque.

Control Function: (with control devices fitted)

The swivel angle of the bent axis can be changed, for example, mechanically via an adjusting spindle or hydraulically via an adjusting piston. The hydraulic section of the rotary group cylinder complete with control lens (port plate) is swivelled out and, depending on the type of circuit and function, is held in the zero or starting position by either mechanical or hydraulic means. Increasing the swivel angle increases displacement and torque; decreasing the angle gives a corresponding reduction in these values. If the swivel angle is zero, the displacement is also zero.

Mechanical or hydraulic control devices are normally fitted, which can themselves be controlled and regulated by mechanical, hydraulic or electrical means. Well-known types of control are: handwheel control, electro-proportional control, constant horsepower control.

General

Because of the bent-axis design, in both pump and motor operation, the torque is generated direct at the drive shaft. The radial loading of the pistons on the cylinder is very low, giving low wear, high efficiency and good starting torque. The spherical design of the port plate means a torque-free cylinder bearing since all forces acting on the cylinder pass through one point. Axial movement caused by elastic deformation does not increase the leakage losses between cylinder and port plate. When idling and during the start-up process, the cylinder is held against the port plate by the built-in cup springs. As pressure increases, hydraulic forces balance the cylinder so that, even with high loading on the control face between cylinder and port plate, a permanent oil film is maintained and leakage is kept to a minimum. Mounted on the drive shaft is the bearing set which absorbs axial and radial forces. External sealing of the rotary group is by means of radial seal and O-rings. A retaining ring holds the complete rotary group in the housing.

2.1.3 Principles of Calculation

Calculating Pump Size		
	Fixed displacement bent-axis pump	Variable displacement bent-axis pump
Flow	$Q = \frac{V_g \cdot n \cdot \eta_{vol}}{1000}$ (l/min)	$Q = \frac{V_{g\ max} \cdot n \cdot \sin \alpha \cdot \eta_{vol}}{1000 \cdot \sin \alpha_{max}}$ (l/min)
Drive speed	$n = \frac{Q \cdot 1000}{V_g \cdot \eta_{vol}}$ (rpm)	$n = \frac{Q \cdot 1000 \cdot \sin \alpha_{max}}{V_{g\ max} \cdot \eta_{vol} \cdot \sin \alpha}$ (rpm)
Drive torque	$M = \frac{V_g \cdot \Delta p}{20 \pi \cdot \eta_{mh}} = \frac{1,59 \cdot V_g \cdot \Delta p}{100 \cdot \eta_{mh}}$ (Nm)	$M = \frac{V_{g\ max} \cdot \Delta p \cdot \sin \alpha}{20 \pi \cdot \eta_{mh} \cdot \sin \alpha_{max}} = \frac{1,59 \cdot V_{g\ max} \cdot \Delta p \cdot \sin \alpha}{100 \cdot \eta_{mh} \cdot \sin \alpha_{max}}$ (Nm)
Drive power	$P = \frac{2 \pi \cdot M \cdot n}{60\ 000} = \frac{M \cdot n}{9549}$ (kW) $P = \frac{Q \cdot \Delta p}{600 \cdot \eta_{vol} \cdot \eta_{mh}} = \frac{Q \cdot \Delta p}{600 \cdot \eta_t}$ (kW)	$P = \frac{2 \pi \cdot M \cdot n}{60\ 000} = \frac{M \cdot n}{9549}$ (kW) $P = \frac{Q \cdot \Delta p}{600 \cdot \eta_{vol} \cdot \eta_{mh}} = \frac{Q \cdot \Delta p}{600 \cdot \eta_t}$ (kW)

Where:

Q	= flow	(l/min)
M	= drive torque	(Nm)
P	= drive power	(kW)
V_g	= geometric displacement per rev.	(cm ³)
$V_{g\ max}$	= max. geom. displacement per rev.	(cm ³)
n	= speed	(rpm)

α_{max}	= max. swivel angle (varies according to design)
α	= set swivel angle (between 0 and α_{max})
η_{vol}	= volumetric efficiency
η_{mh}	= mechanical - hydraulic efficiency
η_t	= overall efficiency ($\eta_t = \eta_{vol} \cdot \eta_{mh}$)
Δp	= differential pressure (bar)

Calculating Motor Size		
	Fixed displacement bent-axis motor	Variable displacement bent-axis motor
Consumption (Flow)	$Q = \frac{V_g \cdot n}{1000 \cdot \eta_{vol}} \quad (\text{l/min})$	$Q = \frac{V_{g \max} \cdot n \cdot \sin \alpha}{1000 \cdot \eta_{vol} \cdot \sin \alpha_{\max}} \quad (\text{l/min})$
Output speed	$n = \frac{Q \cdot 1000 \cdot \eta_{vol}}{V_g} \quad (\text{rpm})$	$n = \frac{Q \cdot 1000 \cdot \eta_{vol} \cdot \sin \alpha_{\max}}{V_{g \max} \cdot \sin \alpha} \quad (\text{rpm})$
Output torque	$M = \frac{V_g \cdot \Delta p \cdot \eta_{mh}}{20 \pi} = \frac{1,59 \cdot V_g \cdot \Delta p \cdot \eta_{mh}}{100} \quad (\text{Nm})$	$M = \frac{V_{g \max} \cdot \Delta p \cdot \eta_{mh} \cdot \sin \alpha}{20 \pi \cdot \sin \alpha_{\max}} = \frac{1,59 \cdot V_{g \max} \cdot \Delta p \cdot \eta_{mh} \cdot \sin \alpha}{100 \cdot \sin \alpha_{\max}} \quad (\text{Nm})$
Output power	$P = \frac{2 \pi \cdot M \cdot n}{60 \cdot 1000} = \frac{M \cdot n}{9549} \quad (\text{kW})$ $P = \frac{Q \cdot \Delta p}{600} \cdot \eta_{vol} \cdot \eta_{mh} = \frac{Q \cdot \Delta p \cdot \eta_t}{600} \quad (\text{kW})$	$P = \frac{2 \pi \cdot M \cdot n}{60 \cdot 1000} = \frac{M \cdot n}{9549} \quad (\text{kW})$ $P = \frac{Q \cdot \Delta p}{600} \cdot \eta_{vol} \cdot \eta_{mh} = \frac{Q \cdot \Delta p \cdot \eta_t}{600} \quad (\text{kW})$

Es ist hierbei:

- Q = consumption (flow) (l/min)
- M = output torque (Nm)
- P = output power (kW)
- V_g = geometric displacement per rev. (cm³)
- V_{g max} = max. geom. displacement per rev. (cm³)
- n = speed (rpm)

- α_{max} = max. swivel angle (varies according to design)
- α = set swivel angle (between 0 and α_{max})
- η_{vol} = volumetric efficiency
- η_{mh} = mechanical - hydraulic efficiency
- η_t = overall efficiency (η_t = η_{vol} · η_{mh})
- Δp = differential pressure (bar)

2.1.4 Rotary Group Forces

Parallelogram illustrating forces in a Fixed Displacement Unit.

The resolution of forces takes place on the drive flange, i.e. direct on the drive shaft. This conversion from torque into piston force in the pump, and in reverse in the motor, guarantees the best possible efficiency. A *single* resolution means a *single* efficiency loss!

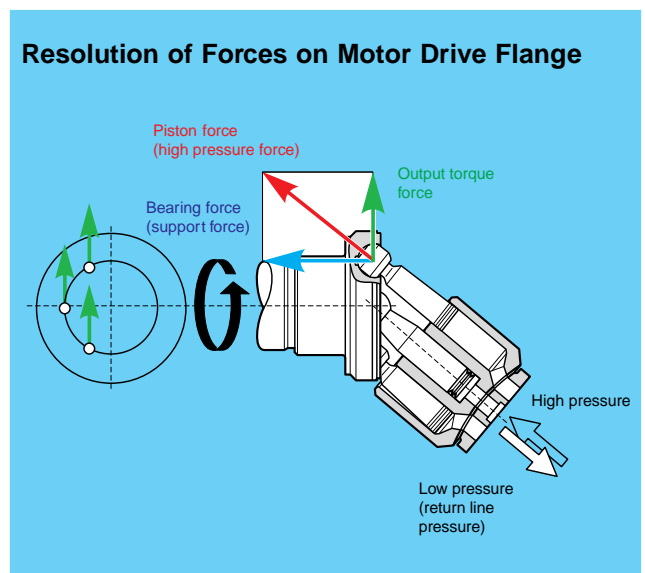
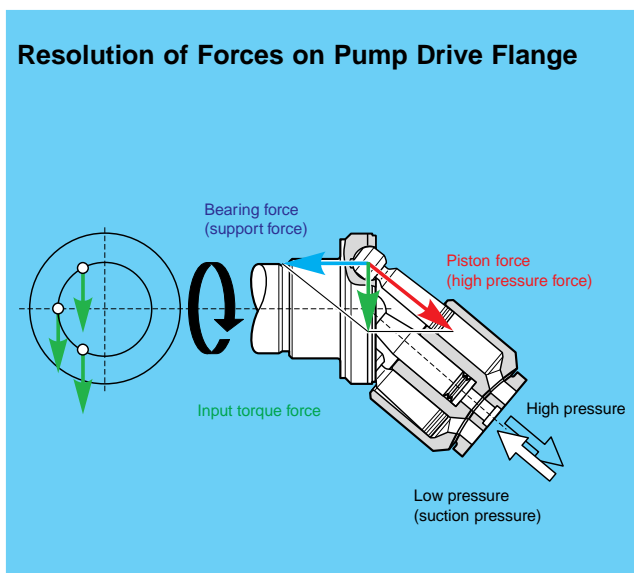

Resolution of Forces on Port Plate with Spherical Control Face

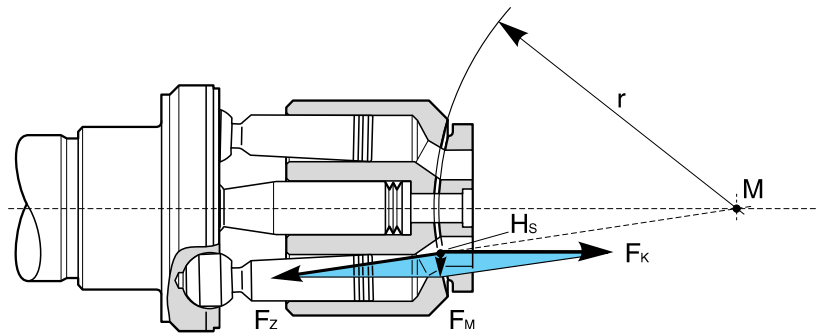

For this torque illustration, a segment of the hydraulic rotary group has been cut out and shown in simplified form in pure *static* condition with swivel angle 0° .

In practice, when the rotary group is swivelled out, *dynamic* loading is present since 3 or 4 of the piston areas are always under high pressure.

- M = centre of assumed (theoretical) sphere
- r = radius of this sphere
- H_s = focal point of hydrostatic bearing pressure field
- F_K = sum of the force of 3 or 4 pistons
- F_Z = force of hydrostatic pressure field of cylinder
- F_M = resulting force on centre pin

2.1.5 40° Tapered Piston, Bent-Axis Rotary Group

Shown here in housing with fixed swivel angle

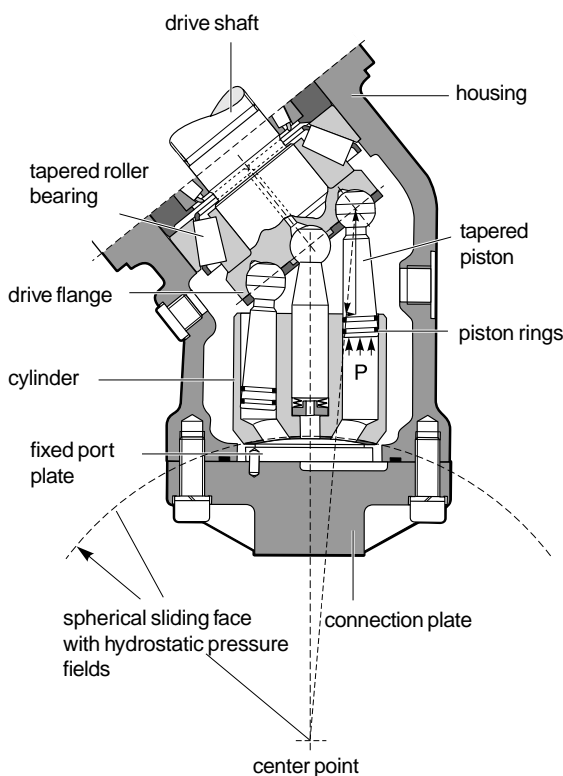

- central swivel point
- cardanless cylinder drive
- torque-free cylinder bearing
- self-centring rotary group
- spherical port plate
- tapered roller bearings
- one-piece tapered piston with 2 piston rings
- automatic bearing lubrication
- piston-force resolution direct on drive flange

2.1.6 Examples of Types

Fixed Displacement Unit A2F
(fixed swivel angle)

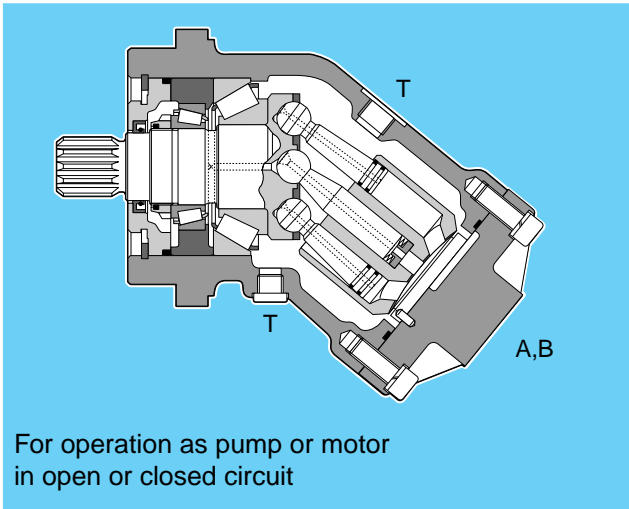

Variable Displacement Unit A7VO
(variable swivel angle)

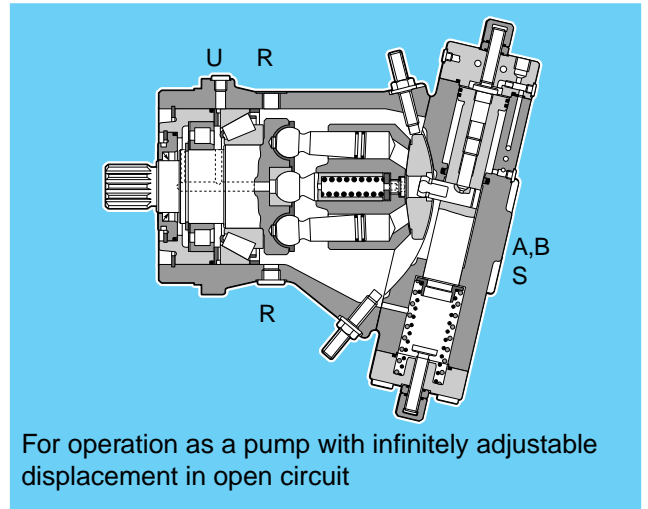

2.1.7 Symbols

Symbolic illustration of the best-known types

- A,B** Pressure ports
- S** Suction port
- T,R** Case drain ports
- U** Flushing port

A2FM
Fixed motor

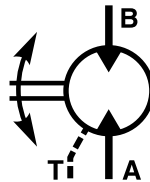
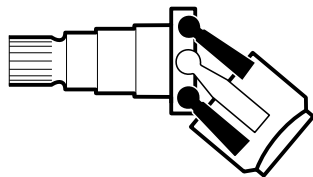

Fixed displacement motor for open or closed circuits; fixed swivel angle; both directions of rotation of power take-off.

A6VM
Variable motor

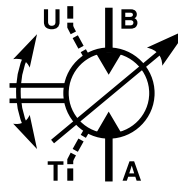
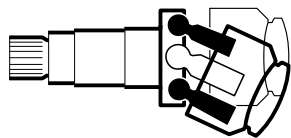

Variable displacement motor for open and closed circuits, swivel to one side only; infinitely variable swivel angle; both directions of rotation of power take-off.

A7VO
Variable pump

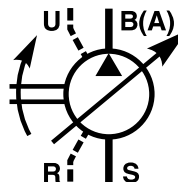
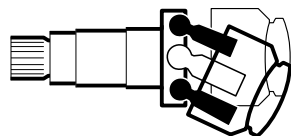

Variable displacement pump for open circuits, swivel to one side only; infinitely variable swivel angle; single direction of rotation of drive.

A2V
Variable pump

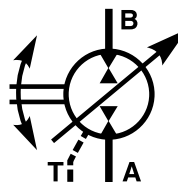
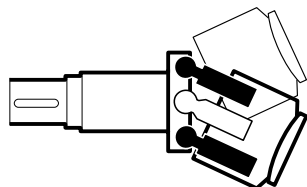

Variable displacement pump for closed circuits, swivel to both sides; swivel angle infinitely variable over centre; both directions of rotation of drive.

2.2 Swashplate

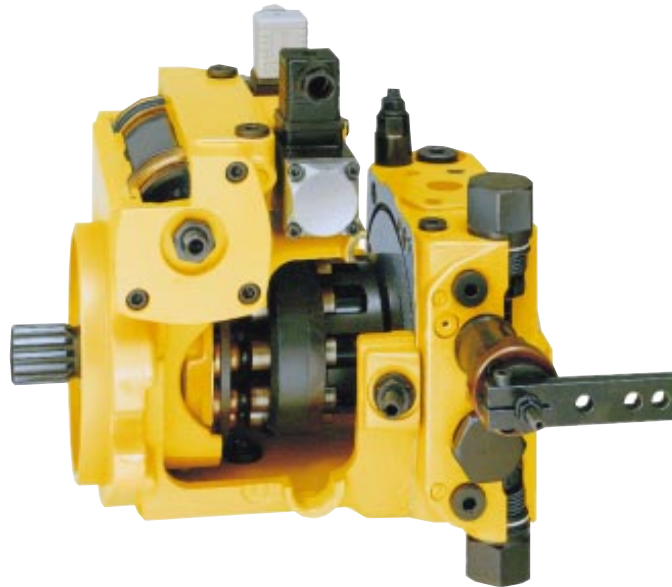

Example:
Variable Displacement Pump with electro-hydraulic control,
speed-related closed loop control and built-on auxiliary pump

Schematic Diagram of a Swashplate (with parallel-axis pistons) with fixed or variable swivel angle α

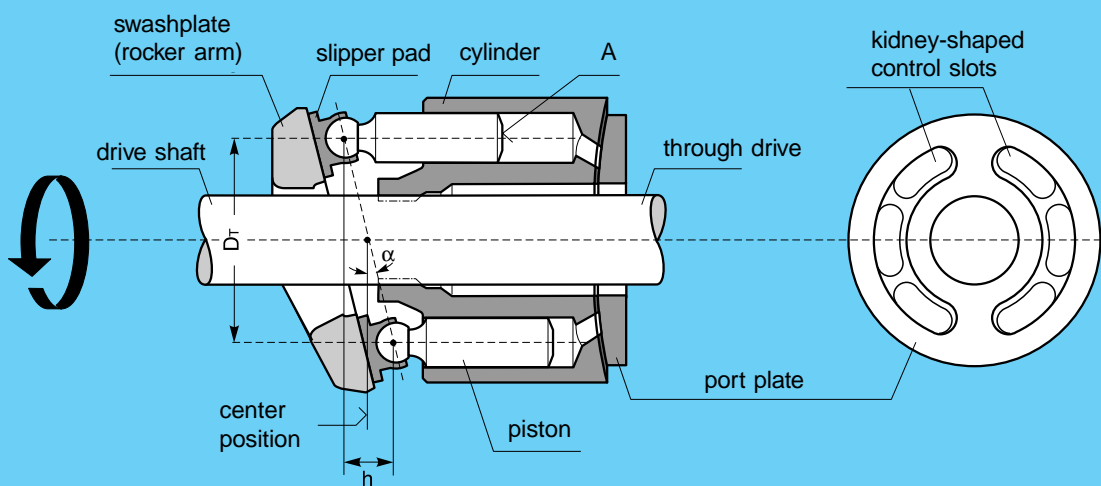

- h = piston stroke
- A = piston area
- D_T = pitch diameter, when $\alpha = 0$
- α = swivel angle (e.g. 20°)
- V_g = geom. displacement [cm^3/rev]
- x = number of pistons (e.g. 9)

$$h = D_T \cdot \tan \alpha$$

$$V_g = x \cdot A \cdot h$$

$$V_g = x \cdot A \cdot D_T \cdot \tan \alpha$$

2.2.1 Swashplate Principle

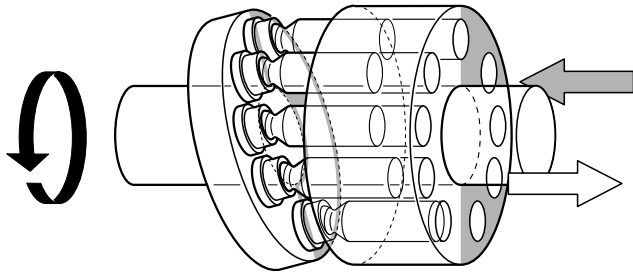

The *swashplate* rotary group is a displacement unit whose displacement pistons are arranged axially to the drive shaft and are supported against a tilted plate (swashplate).

Pump Function:

Through the gearing, rotation of the drive shaft also causes the cylinder to rotate. The pistons execute a stroke within the cylinder bores dependent on the tilt angle of the *swashplate*. The hydraulic medium is fed

to the low pressure (inlet) side of the pump and pumped out by the pistons on the high pressure (outlet) side into the system.

Motor Function:

In motor operation, the process is reversed and pressure oil is fed to the inlet side of the unit. The pistons perform a stroke, taking the cylinder with them. Via the gearing, this, in turn, causes the drive shaft to rotate. Oil exits on the low pressure (outlet) side and flows back into the system.

Swashplate Angle:

In the fixed displacement unit, the angle of the swashplate is fixed within the housing. In the variable unit, this angle is infinitely variable within specific limits. Changing the swashplate angle changes the piston stroke, thus varying the displacement.

2.2.2 Description of Function

Example: Variable Displacement Pump

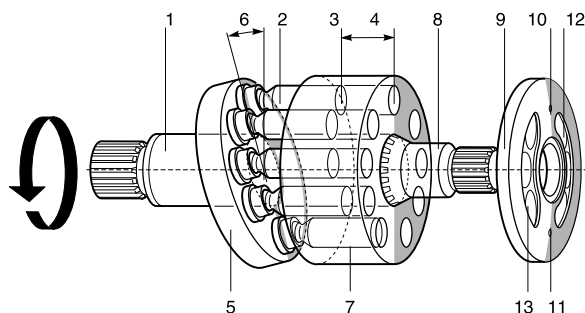

- | | |
|-------------------------|---|
| 1 = drive shaft | 8 = through drive |
| 2 = piston | 9 = port plate |
| 3 = piston area | 10 = upper dead point OT |
| 4 = piston stroke | 11 = lower dead point UT |
| 5 = swashplate | 12 = control slot, pressure side
(for direction of rotation shown) |
| 6 = angle of adjustment | 13 = control slot, suction side
(for direction of rotation shown) |
| 7 = cylinder | |

Description

The axial piston units of swashplate design, with fixed or variable displacement, can operate as hydraulic pumps or motors.

When used as a pump, the flow is proportional to the input speed and the swashplate angle. If the unit is used as a motor, the output speed is proportional to the flow through the unit.

The input (pump) or output (motor) torque increases with the pressure drop between the high and low pressure sides.

In pump operation, mechanical energy is converted into hydrostatic power while in motor operation,

inversely, hydrostatic power is converted into mechanical energy.

By adjusting the swashplate angle of a variable pump or motor it is possible to *vary* the displacement and thus the flow.

Function

... as a pump:

Driven by the prime mover, (e.g. diesel or electric motor), the drive shaft rotates and, via the gearing, also causes the cylinder to rotate, taking with it the nine pistons. The pistons are held against the sliding surface of the swashplate by the slipper pads and carry out a stroke. The slipper pads are held against the sliding surface and guided by means of a return device. As the cylinder rotates, each piston moves through the lower or upper dead point and back to its starting position. A movement from one dead point to the other (where the direction of movement is reversed) constitutes one complete stroke during which a volume of hydraulic fluid, corresponding to the piston area and the stroke, is either *sucked in* or *pumped out* via the two control slots in the portplate.

During the *suction* stroke, the hydraulic fluid is sucked - in reality *compressed* - by atmospheric pressure in open circuits, and by the boost pressure in closed circuits, into the piston area as it increases in size. During the *pressure stroke*, fluid is pushed out through the piston bores on the opposite side into the hydraulic system.

... as a motor:

The motor function is the reverse of the pump function. In this case, hydraulic fluid is fed from the system to the hydraulic motor. Oil flows via the connection plate through a control slot to the cylinder bores. 4 or 5 cylinder bores are located over the pressure side control slot. The remaining cylinder bores are located over the other control slot and are either connected with the return-line side, or may be closed when directly above the connecting strip between the two control slots. Application of pressure to the piston causes it to slide down the swashplate, taking the cylinder with it. The cylinder and the nine connected pistons rotate with the drive shaft and the pistons carry out a stroke. Hydraulic pressure generates a torque at the cylinder and thus the rotation of the drive shaft. The output speed is determined by the volume of flow into the motor.

Control Function: (with control devices fitted)

The angle of the swashplate can be changed, for example, mechanically via a pivot pin or hydraulically via an adjusting piston. The swashplate/rocker arm is mounted on roller or plain bearings and the zero position is spring-centred. Increasing the swivel angle increases displacement and torque, decreasing the angle gives a corresponding reduction in these values. If the swivel angle is zero, the displacement is also

zero. Mechanical or hydraulic control devices are normally fitted, which can themselves be controlled and regulated by mechanical, hydraulic or electrical means. Well-known types of control are: electro-proportional control, constant pressure control (zero stroke control), constant horsepower control.

General

Swashplate-type pumps and motors are suitable for application in open and closed circuits. Because of their design, they are used predominantly as pumps in closed circuits. The possibility of mounting auxiliary or secondary pumps on the through drive and of making use of the integrated design of controls and valves offers a number of advantages. Through this compact and lightweight arrangement, longer service life may be expected since the slipper pads are mounted on *hydrostatic* bearings (plain bearings). The resolution of forces (piston forces/torque) takes place on the swashplate via the slipper pad. Forces within the hydraulic section of the rotary group, ie. cylinder with pistons and port plate, are balanced. The drive shaft bearings allow external forces to be absorbed. The principle of the spherical control area, its lubrication, the pre-tensioning of the cylinder via cup springs, etc., are similar to that of the bent-axis rotary group.

2.2.3 Principles of Calculation

Calculating Pump Size		
	Fixed displacement swashplate pump	Variable displacement swashplate pump
Flow	$Q = \frac{V_g \cdot n \cdot \eta_{vol}}{1000}$ (l/min)	$Q = \frac{V_{g\ max} \cdot n \cdot \tan \alpha \cdot \eta_{vol}}{1000 \cdot \tan \alpha_{max}}$ (l/min)
Drive speed	$n = \frac{Q \cdot 1000}{V_g \cdot \eta_{vol}}$ (rpm)	$n = \frac{Q \cdot 1000 \cdot \tan \alpha_{max}}{V_{g\ max} \cdot \eta_{vol} \cdot \tan \alpha}$ (rpm)
Drive torque	$M = \frac{V_g \cdot \Delta p}{20 \pi \cdot \eta_{mh}} = \frac{1,59 \cdot V_g \cdot \Delta p}{100 \cdot \eta_{mh}}$ (Nm)	$M = \frac{V_{g\ max} \cdot \Delta p \cdot \tan \alpha}{20 \pi \cdot \eta_{mh} \cdot \tan \alpha_{max}} = \frac{1,59 \cdot V_{g\ max} \cdot \Delta p \cdot \tan \alpha}{100 \cdot \eta_{mh} \cdot \tan \alpha_{max}}$ (Nm)
Drive power	$P = \frac{2 \pi \cdot M \cdot n}{60\ 000} = \frac{M \cdot n}{9549}$ (kW) $P = \frac{Q \cdot \Delta p}{600 \cdot \eta_{vol} \cdot \eta_{mh}} = \frac{Q \cdot \Delta p}{600 \cdot \eta_t}$ (kW)	$P = \frac{2 \pi \cdot M \cdot n}{60\ 000} = \frac{M \cdot n}{9549}$ (kW) $P = \frac{Q \cdot \Delta p}{600 \cdot \eta_{vol} \cdot \eta_{mh}} = \frac{Q \cdot \Delta p}{600 \cdot \eta_t}$ (kW)

Where:

Q	= flow	(l/min)
M	= drive torque	(Nm)
P	= drive power	(kW)
V_g	= geometric displacement per rev.	(cm ³)
$V_{g\ max}$	= max. geometric displacement per rev.	(cm ³)
n	= speed	(rpm)

α_{max}	= max. swivel angle (varies according to design)
α	= set swivel angle (between 0 and α_{max})
η_{vol}	= volumetric efficiency
η_{mh}	= mechanical - hydraulic efficiency
η_t	= overall efficiency ($\eta_t = \eta_{vol} \cdot \eta_{mh}$)
Δp	= differential pressure (bar)

Calculating Motor Size		
	Fixed displacement swashplate motor	Variable displacement swashplate motor
Consumption (Flow)	$Q = \frac{V_g \cdot n}{1000 \cdot \eta_{vol}} \quad (\text{l/min})$	$Q = \frac{V_{g \max} \cdot n \cdot \tan \alpha}{1000 \cdot \eta_{vol} \cdot \tan \alpha_{\max}} \quad (\text{l/min})$
Output speed	$n = \frac{Q \cdot 1000 \cdot \eta_{vol}}{V_g} \quad (\text{rpm})$	$n = \frac{Q \cdot 1000 \cdot \eta_{vol} \cdot \tan \alpha_{\max}}{V_{g \max} \cdot \tan \alpha} \quad (\text{rpm})$
Output torque	$M = \frac{V_g \cdot \Delta p \cdot \eta_{mh}}{20 \pi} = \frac{1,59 \cdot V_g \cdot \Delta p \cdot \eta_{mh}}{100} \quad (\text{Nm})$	$M = \frac{V_{g \max} \cdot \Delta p \cdot \eta_{mh} \cdot \tan \alpha}{20 \pi \cdot \tan \alpha_{\max}} = \frac{1,59 \cdot V_{g \max} \cdot \Delta p \cdot \eta_{mh} \cdot \tan \alpha}{100 \cdot \tan \alpha_{\max}} \quad (\text{Nm})$
Output power	$P = \frac{2 \pi \cdot M \cdot n}{60 \, 000} = \frac{M \cdot n}{9549} \quad (\text{kW})$ $P = \frac{Q \cdot \Delta p}{600} \cdot \eta_{vol} \cdot \eta_{mh} = \frac{Q \cdot \Delta p \cdot \eta_t}{600} \quad (\text{kW})$	$P = \frac{2 \pi \cdot M \cdot n}{60 \, 000} = \frac{M \cdot n}{9549} \quad (\text{kW})$ $P = \frac{Q \cdot \Delta p}{600} \cdot \eta_{vol} \cdot \eta_{mh} = \frac{Q \cdot \Delta p \cdot \eta_t}{600} \quad (\text{kW})$

Where:

- Q = consumption (flow) (l/min)
- M = output torque (Nm)
- P = output power (kW)
- V_g = geometric displacement per rev. (cm³)
- V_{g max} = max. geom. displacement per rev. (cm³)
- n = speed (rpm)

- α_{max} = max. swivel angle (varies according to design)
- α = set swivel angle (between 0 and α_{max})
- η_{vol} = volumetric efficiency
- η_{mh} = mechanical - hydraulic efficiency
- η_t = overall efficiency (η_t = η_{vol} • η_{mh})
- Δp = differential pressure (bar)

2.2.4 Rotary Group Forces

Parallelogram illustrating forces in a variable displacement unit, e.g. with piston angled inwards

The resolution of forces takes place on the swashplate in the slipper pads and the cylinder. The piston slipper pads are on hydrostatic bearings, and guarantee long service life of the rotary groups.

Resolution of Forces on the Pump Swashplate

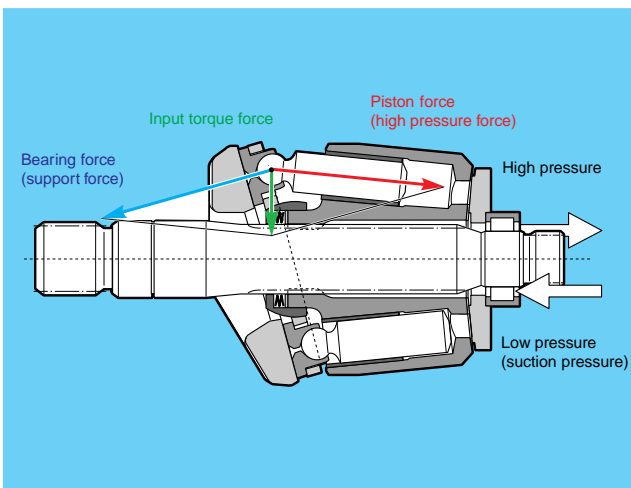

Resolution of Forces on the Motor Swashplate

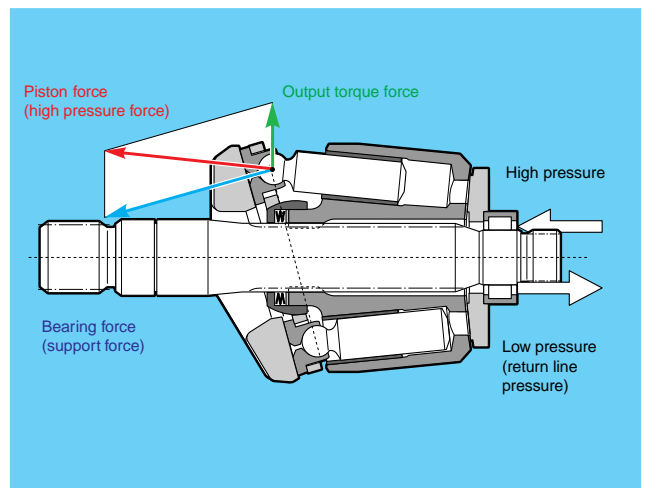

2.2.5 Swashplate Rotary Group

Simplified illustration

The basic components of a swashplate rotary group are **cylinder**, **piston** and **swashplate**.

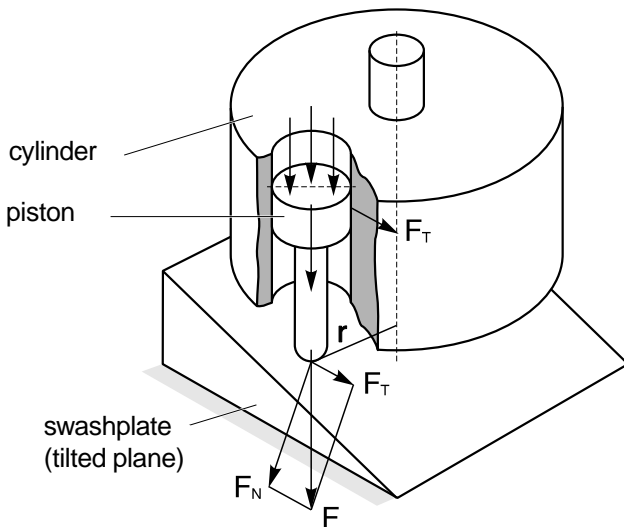

e.g. as a motor:

As explained in the Description of Function, the piston is pressurised by oil from the pump and pressed against the tilted plate.

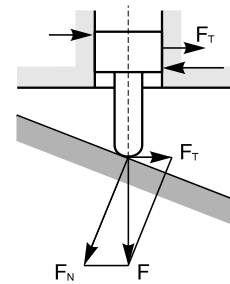

The resolution of the piston forces at the point of contact (plain bearing) with the tilted plate produces a bearing-force and a torque-force component (F_N and F_T). The piston slides down the tilted plate and carries out a stroke, taking with it the cylinder and drive shaft. However, because of the movement allowed by the piston tolerance within the cylinder bore, at the point of break-away (start-up), a greater frictional resistance occurs (static friction) than during a normal stroke (sliding friction). This 2-fold resolution of forces is the reason for the slightly lower starting efficiency of the *swashplate* unit as compared to the single resolution of forces in the case of the *bent-axis* unit. In practice, this can be important in motor operation, but is of little significance in pump operation.

2.2.6 Examples of Types

Variable Pump for Closed Circuits A4VG

High pressure range up to 450 bar

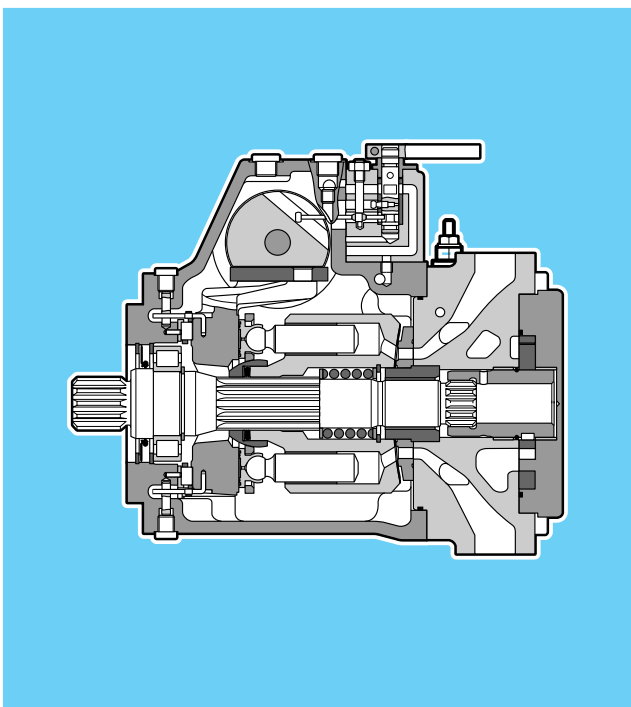

Variable Pump for Open Circuits A10VO

Medium pressure range up to 315 bar

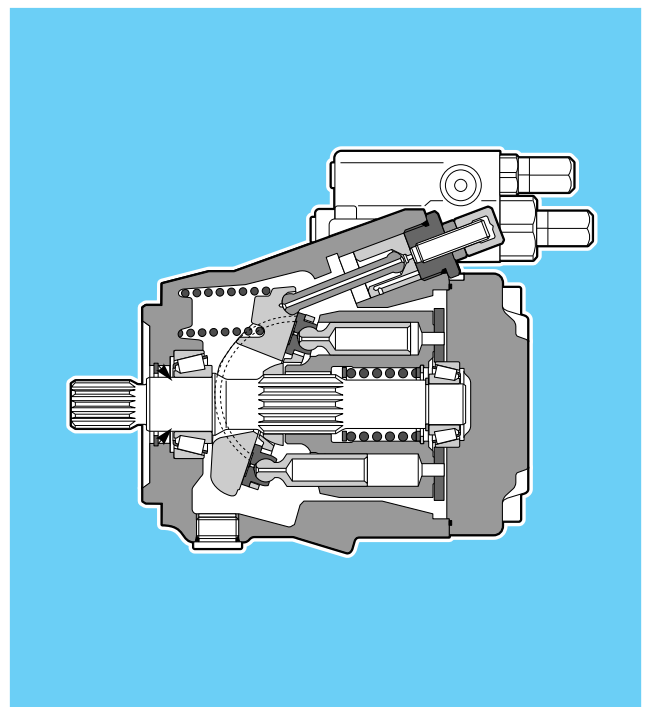

2.2.7 Symbols

Symbolic illustration of the best-known types

- A,B** Pressure ports
- S** Suction port
- T,R,L** Case drain ports
- U** Flushing port

A4VG

Variable Pump

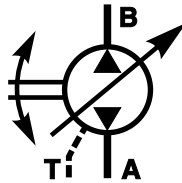
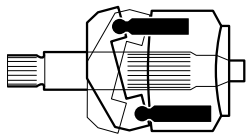

Variable displacement pump for closed circuits, swivel to both sides; swivel angle infinitely variable over centre; both directions of rotation of drive; tandem version possible by mounting additional pump at the through drive.

A4VSO/G/H

Variable Pump

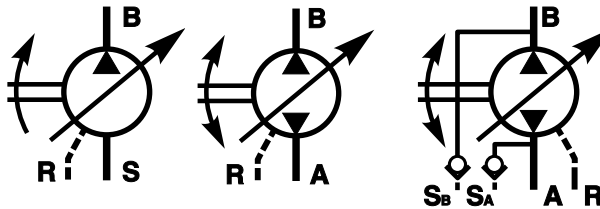
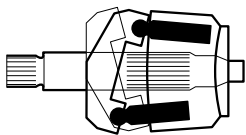

Variable displacement pump for open, closed or semi-closed circuits; swivel angle infinitely variable; single or both directions of rotation of drive and flow direction, depending on the type of circuit; auxiliary pump may be mounted at the through drive.

A4FM

Fixed Motor

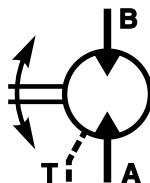
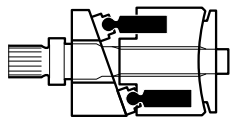

Fixed displacement motor for open or closed circuits; fixed swivel angle; both directions of rotation of power take-off; possibility of through drive for mounting brake.

A10VO

Variable Pump

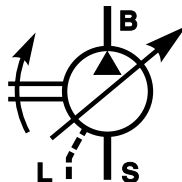
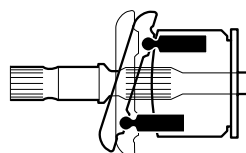

Variable displacement pump for open circuits, swivel to one side only; infinitely variable swivel angle; single direction of rotation of drive.

A11VLO

Variable Pump

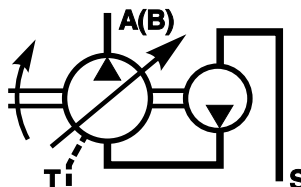
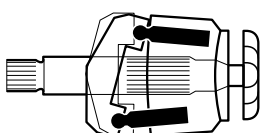

Variable displacement pump for open circuits, swivel to one side only; infinitely variable swivel angle; single direction of rotation of drive; with built-on charging pump at through drive.

3 Components

3.1 Fixed displacement motors and pumps of bent axis design

With high performance, modern axial-tapered piston rotary groups, series 6

Important Features:

- Cardanless cylinder drive via tapered pistons
- tapered pistons with piston ring seals
- robust tapered roller bearings with long service life
- flange and shaft end to ISO or SAE standards
- two drain ports and flushing port for bearings as standard
- direct mounting of brake valve possible
- models available for special applications
- nominal pressure up to 400 bar, peak pressure up to 450 bar

3.1.1 Fixed Motor

Operation as a motor in open and closed circuits; used in mobile and industrial applications, wherever a constant displacement is required for hydrostatic power transmission.

3.1.2 Fixed Pump

With a suitable connection plate fitted, the A2FM motor becomes the A2FO pump (not illustrated) which is suitable for open circuits and is noted for its robustness, reliability, long service life and quiet operation.

3.1.3 Fixed Pump for Trucks

Pump with special characteristics and dimensions for applications in mobile trucks; it is designed for a pressure range of 250/350 bar. If it is necessary to change the direction of rotation (e.g. with change of gearbox), this is simply carried out on the open-circuit pump by rotating the connection plate.

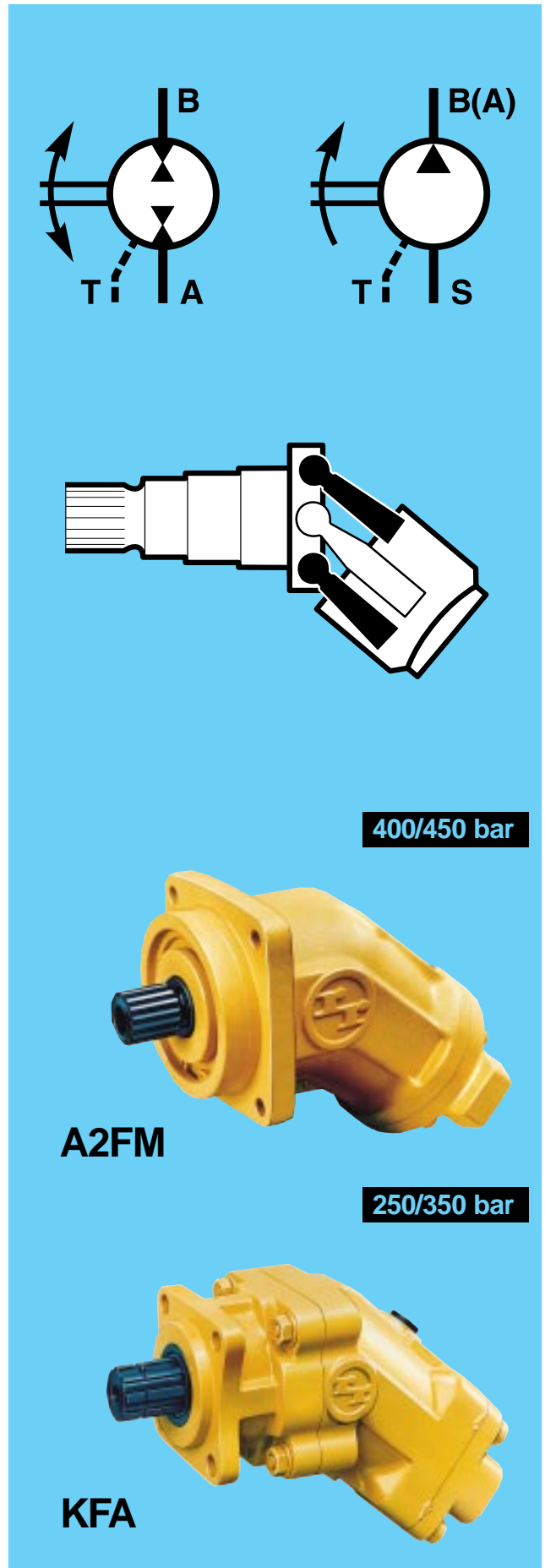

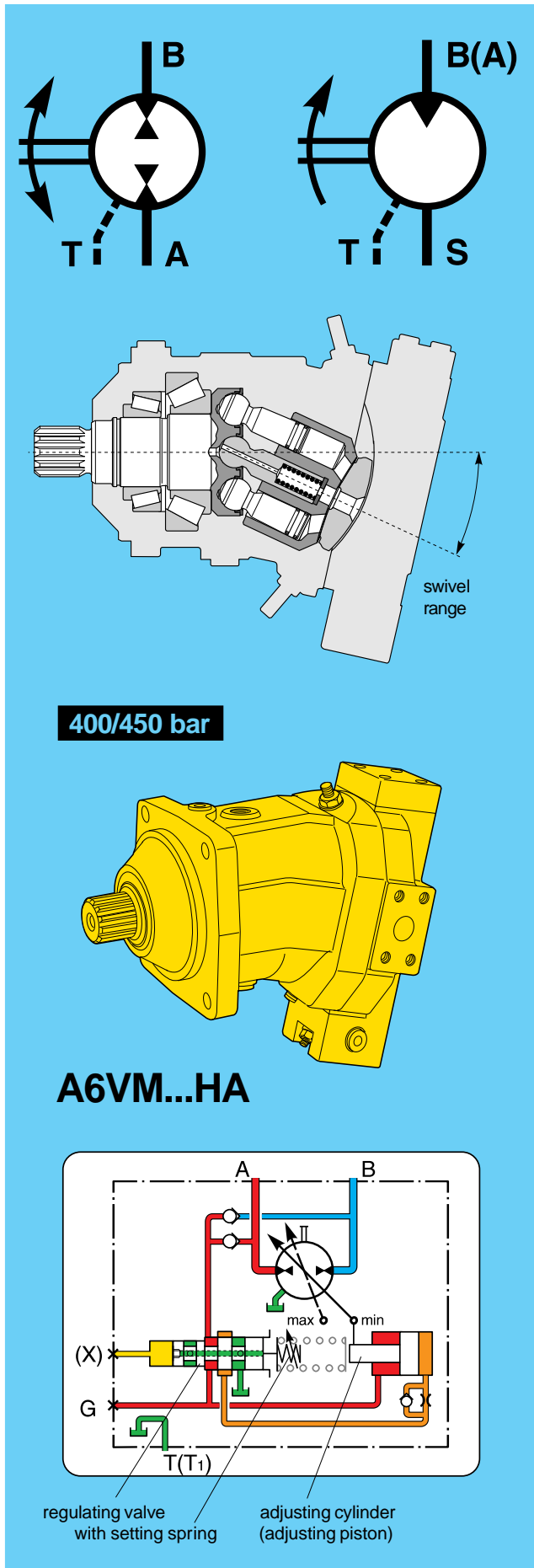

3.2 Variable Motor of Bent-Axis Design for Open and Closed Circuits

Important Features:

- gives greater control range for hydrostatic transmissions
- fulfils the requirement for high speed and high torque
- cost-saving through elimination of gearbox, and possibility of using smaller pumps
- low unit power
- good starting characteristics
- various control and regulating devices
- swivel to one side only
- nominal pressure 400 bar, peak pressure 450 bar

3.2.1 Automatic Control, High-Pressure-related

The A6VM variable motor has a bent-axis rotary group. The torque is therefore generated direct on the drive shaft and the cylinder is driven without a Cardan coupling directly by the tapered pistons. The swivel angle of the rotary group may be changed by moving the control lens along a spherical surface by means of the adjusting piston. Provided that the pump flow and high pressure remain constant, then

- reducing the angle gives higher speed and lower torque
- increasing the angle gives higher torque and lower speed.

The code ... HA refers to the high-pressure-related control of this motor. The displacement is set automatically dependent on operating pressure. When the operating pressure set with the regulating valve - measured internally via A or B - is reached, the motor is swivelled from $V_{g \text{ min}}$ to $V_{g \text{ max}}$. Below this pressure, the motor remains at minimum swivel angle.

HA curve
Automatic control
high-pressure-related

p_B = operating pressure
 V_g = displacement

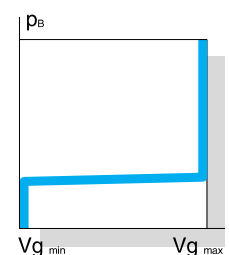

3.3 Variable Pump of Bent-Axis Design, for Open Circuits

Important features:

- axial-tapered piston rotary group
- Cardanless cylinder drive via tapered pistons
- robust bearings with long service life
- displacement variable between V_{g0} and V_{gmax}
- constant horsepower control with exact hyperbolic curve
- constant pressure control, hydraulic and electric control devices, load-sensing operation possible
- high pressure range up to 350/400 bar
- for use in mobile and industrial applications

3.3.1 High Pressure Applications

The A7VO is a variable pump with internal drain for open hydraulic circuits. The bent-axis rotary group is characterised by its robustness and good self-priming properties. The drive shaft bearings also allow external forces to be absorbed. For particularly demanding requirements in terms of force absorption and running time, type A7VLO has a rotary group with specially strengthened bearings.

The swivel angle of the rotary group is changed by moving the control lens along a spherical surface by means of an adjusting piston. Increasing the angle increases the pump flow and the required drive torque.

Reducing the angle reduces the pump flow and the required drive torque. The maximum angle is e.g. 25° or 26,5°. The minimum 0°. The pump is controlled as a function of the operating pressure, and adjusted by means of external control signals. The necessary control pressure is taken from the pressure side via a check valve.

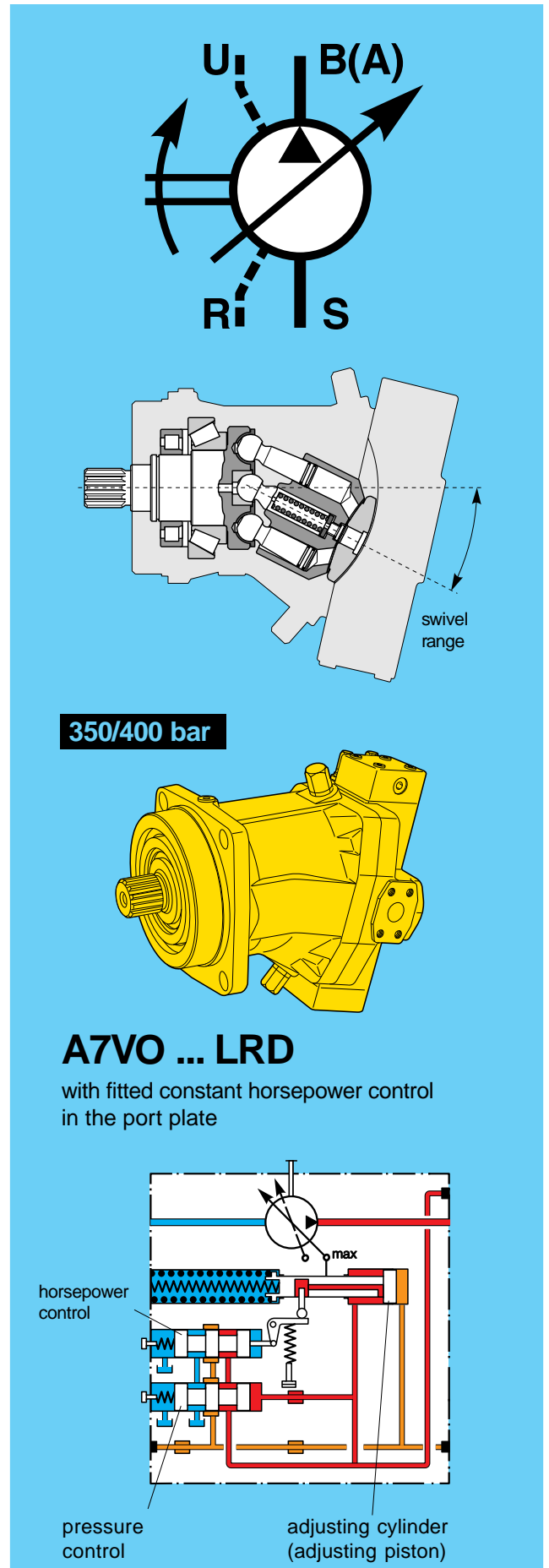

A7VO ... LRD

with fitted constant horsepower control in the port plate

3.3.2 Constant Horsepower Control LR (see Spring-Loaded Control/Hyperbolic Control)

The control holds the pump input torque M [Nm] constant. The constant horsepower control is a function of this constant torque in combination with a constant input speed n [1/min]. On one side we have the input mechanical drive power $P = M \cdot n$ [kW], on the other the hydraulic output power $P = Q \cdot p$ [kW]. While operating pressure p [bar] is dependent on load, flow Q [l/min] can be varied by changing the swivel angle.

Similar to a computer, the control continuously multiplies pressure and flow, and compares the result with the set value. Any upward drift is corrected by reducing the swivel angle and, inversely, by increasing the swivel angle. The control is adjustable (screwing in the setting screw increases the set value).

Start of control is at max. swivel angle. The position at end of control is dependent on the maximum pressure. Alternatively, both end values can be limited by the stop screws. Warning: if the maximum set angle is increased there is a danger of cavitation in the pump and of over-speeding of the hydraulic motor! Increasing the minimum set angle can lead to overloading of the prime mover in the high pressure range.

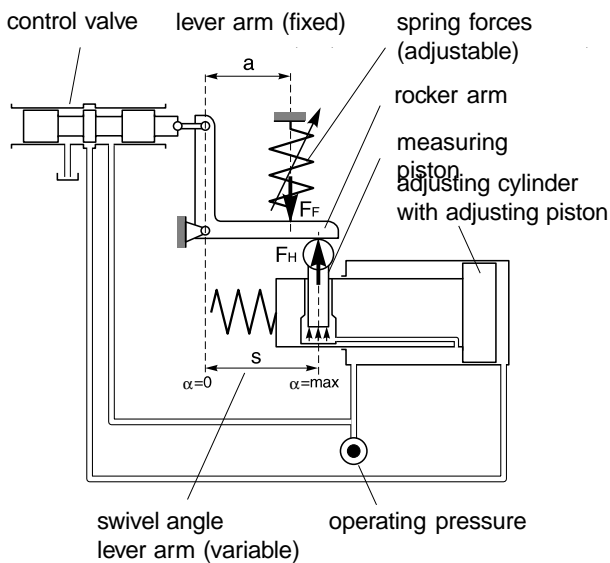

Operating pressure acts via a measuring piston in the adjusting piston on a rocker arm. The opposed spring force, externally adjustable, determines the power setting. If operating pressure p exceeds the permissible value, calculated from the formula $P = Q \cdot p$ [kW], the rocker arm actuates the control valve and the pump is destroyed. The pump flow is reduced until the product of $Q \cdot p$ once again corresponds to the available power. The ideal power hyperbola is achieved, the drive is not overloaded, because of the "constant HP control". Inversely, the pump flow can, depending on operating pressure and supported by a return spring, be increased up to its maximum value.

Spring-loaded Control with approximated curve

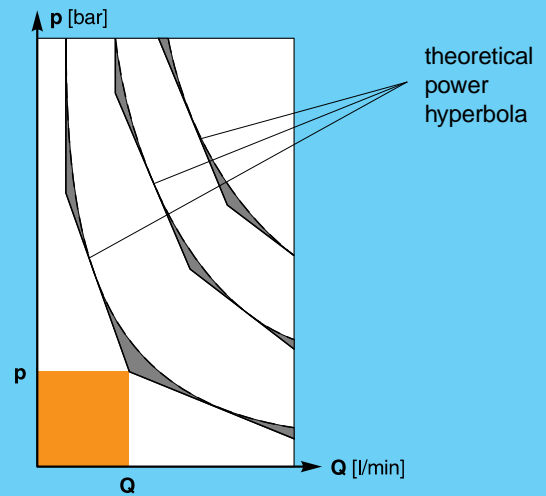

Hydraulic Power Formula : $P = Q \cdot p$ [kW] = constant

- power matching possible by changing the spring package
- power losses in the range shown by shaded section
- no zero swivel, i.e. residual flow against high pressure generates heat

Hyperbolic Control with ideal hyperbolic curve

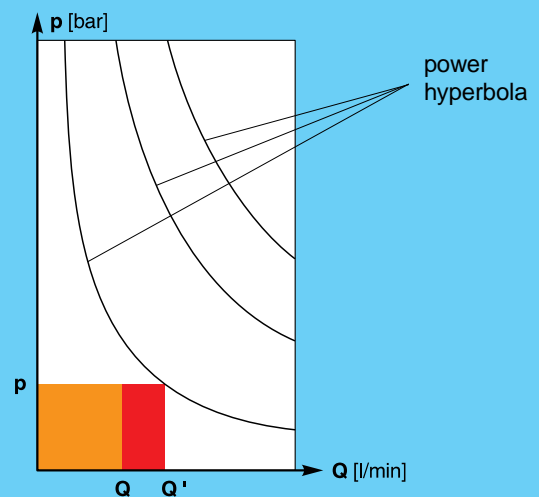

Hydraulic Power Formula : $P = Q' \cdot p$ [kW] = constant

- optimum power matching by infinitely variable spring force, settable externally
- zero swivel, i.e. no residual flow, generating less heat

3.3.3 Variable Double Pump with 2 parallel Bent Axis Rotary Groups

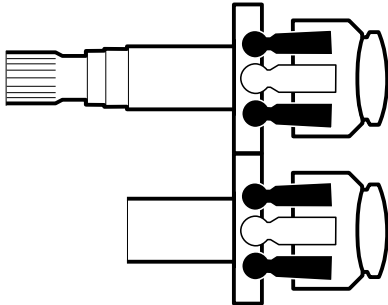

Two variable pumps - one drive. An advantageous combination of two individual pumps with integral distributor gear.

Models with secondary drive and/or auxiliary pump for the supply of additional hydraulic circuits are today standard, particularly in mobile applications.

As an extension of the constant horsepower control for a single pump (A7VO..LR - see pages 18/19), the double pump A8VO..SR with *summed horsepower control* is used, for example, for two parallel hydraulic circuits where the total drive power is split between the two circuits proportional to the pressures in both circuits.

The high pressure signal is averaged in the summation valve and used as the reference value. The ideal hyperbolic power curve is achieved when the torque forces acting on the rocker arm of the constant horsepower control are in balance.

The max. hydraulic torque, which is the product of high pressure force F_H and swivel stroke s , may not exceed the mechanical torque occurring as a product of the adjustable spring force F_F and the fixed lever arm a .

Since the operating pressure p is predetermined by the hydraulic system and the pump can only change its flow Q , if the max. allowable power is exceeded, the pump is automatically swivelled back to a smaller angle. Swivel stroke s is reduced until the resulting hydraulic torque is once again equal to the given mechanical torque.

In practice, both individual or combined controls find application. Common variations are load-limit control, three-circuit control, load sensing, etc.

350/400 bar

A8VO...SR

Hyperbolic Control
Summed HP control curve

Q = flow
 p_1 = operating pressure 1 . pump at A_1
 p_2 = operating pressure 2 . pump at A_2

Double pump
with summed HP control

constant
HP control:
hyperbolic control

adjustable
spring force

summed pressure
valve
($p_1 + p_2$)

3.4 Variable Pump of Bent Axis Design for universal industrial applications

O = open circuit
G = closed circuit
H = semi-closed circuit

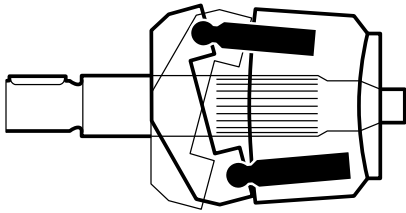

The A4VS.. variable pump is universally suitable for use in the various types of circuit (O-C-S). A wide range of controls and pump models are available. For industrial applications the A4VS..G pump e.g. (operating in closed circuit) can be extended by the addition of relevant adjusting devices and built-on valve block, auxiliary pumps at the through drive, tank and cooler to form a complete hydraulic drive unit. A semi-closed circuit ..H.. may also be extended by the use of anti-cavitation check valves. This will compensate e.g. for differences in volume when operating single rod cylinders.

350/400 bar

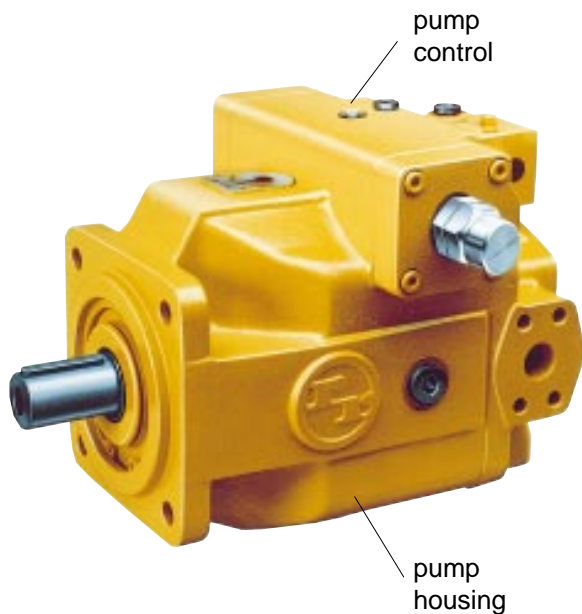

A4VSO

3.4.1 Pump Control Devices of modular design for a variety of control and regulating functions

Examples:

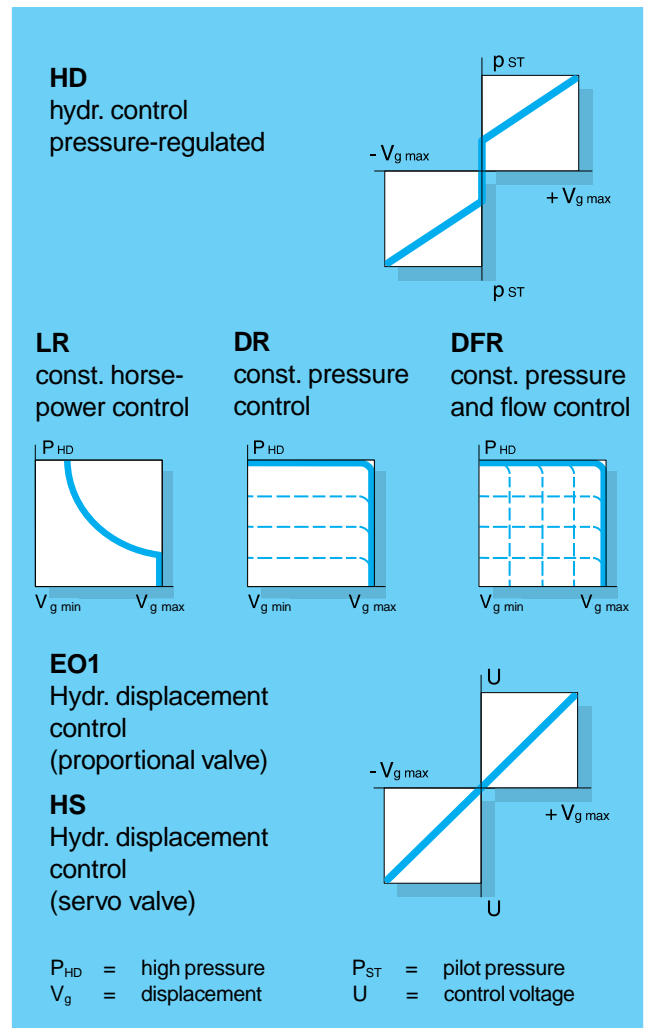

In addition to the recognised advantages of swashplate design the A4VSO pump, developed specially for use in industrial applications, also offers an extremely long bearing service life. Load-sensing control and mooring operation, as well as secondary control, can be achieved with this pump.

The system of closed loop secondary speed control, in combination with a pressure-controlled pump and a secondary-controlled motor, guarantees high control dynamics, accurate speed control, minimal power loss and energy recuperation.

Speed control DS1 regulates the variable unit to produce the necessary torque for the required speed. This torque (in the power supply with impressed pressure) is proportional to the displacement and thus also proportional to the swivel angle. The swivel angle (adjusting distance) is recorded by means of an inductive positional transducer, and the speed is recorded by a tachogenerator.

3.5 Variable Pump of Swashplate Design for medium pressure range in open circuits

Axial piston pump A10V.O is suitable for use in mobile and industrial applications at pressures of up to 280/350 bar. Compared to fixed pump systems it saves energy, e.g. through automatic matching to force (pressure) and speed (flow requirements) by means of a combined constant pressure and flow control.

Besides its compact build, other advantages of the swashplate design are its low unit power, long service life and quiet operation. The through-drive option for mounting of additional pumps is a particularly useful feature.

As a fixed unit at an operating pressure of 280 bar, this is a real alternative to fixed displacement gear or vane type pumps.

Medium High Pressure Range
280/350 bar



A10VSO
DFR
 constant pressure and flow control



P_{HD} = operating pressure
 V_g = flow

$V_{g \min}$ $V_{g \max}$

3.6 Variable Pump of Swashplate Design for simple mobile applications in closed circuit

The A10VG is a variable pump of swashplate design for hydrostatic transmissions in a closed circuit. All necessary valves and an auxiliary pump are integrated. The pump design is such that it can easily be extended to a multiple pump.

The swivel angle of the rotary group is changed, e.g. directly by *turning* the *pivot pin* manually.

If the swivel angle is zero, the pump flow is also zero. Swivelling the pump over centre smoothly reverses the direction of flow.

With the manual pivot pin control, the pin is connected direct to the rocker arm of the rotary group. The angle of rotation of the pin corresponds to the pump swivel angle. The necessary adjustment torque, usually applied by hand or foot force, is influenced by the high pressure and the swivel angle. Limiting of the stroke, or angle of the stroke, or angle of the control mechanism, or possible zero-centring, must be carried out within the control mechanism itself.

In addition to the manual pivot-pin control, hydraulic controls can also be fitted to this pump.

Medium High Pressure Range
300/350 bar

e.g. pivot pin control

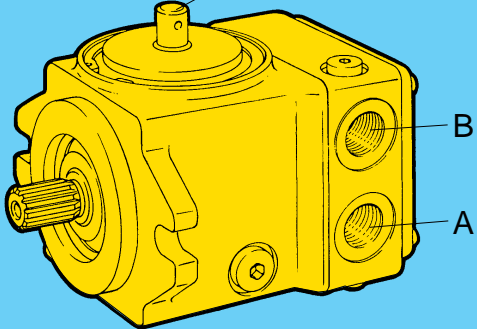

A10VG
 A, B = service lines
 T = tank, S = suction line

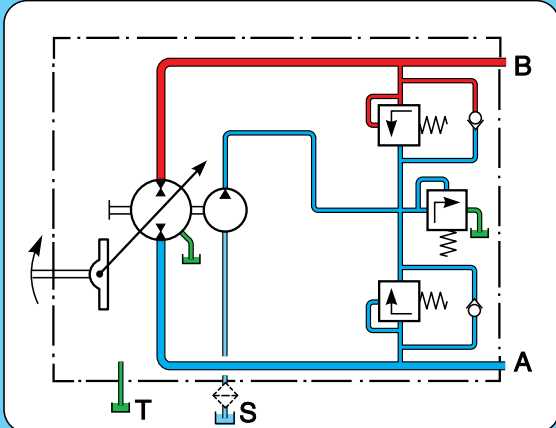

3.7 Variable Pump of Swashplate Design for mobile applications in open circuit with charging pump

The control functions of the A11VLO illustrated here can be operated either super-imposed or as individual functions:

- constant horsepower control with hyperbolic curve
- constant pressure control via sequence valve
- load-sensing control via Δp -control of load-pressure signa

High Pressure Range 350/400 bar

A11VLO

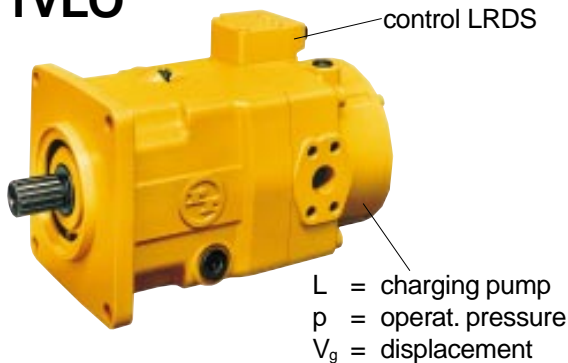

Example:

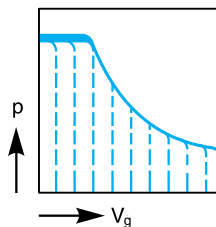
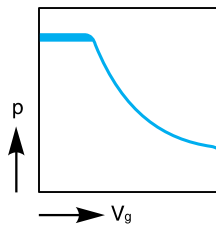
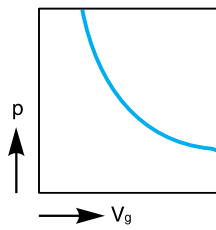

Load-Sensing control

LR

The constant horsepower control regulates the pump displacement in relation to the operating pressure so that a given drive power at constant drive speed is not exceeded.

DR

The constant pressure control causes the pump to swivel back towards $V_g=0$, once the maximum operating pressure has been reached. This function is super-imposed on the constant horsepower control.

LRDS

The load-sensing control operates as a load-pressure dependent flow controller and matches the pump displacement to the flow requirement indicated by the operator. Pump flow is dependent on the opening cross-section of the directional valves, but is not affected by the load pressure in the range below the power curve. The constant power and pressure controls are super-imposed on the load-sensing function.

3.8 Variable Pump of Swashplate Design high-pressure mobile transmissions in closed circuit

We have here in the A4VG DA pump a power pack, complete with all components for closed circuit operation, similar to that described in 3.6. Through hydraulic control with various control devices, we have the typical "mobile pump". This is combined with a fixed or variable motor to give the automatic "mobile transmission".

Illustrated here is the "speed-related automotive control". The pump is controlled by means of the drive speed, operating pressure and, electrically, via 2 switching solenoids. The control energy is taken from the boost circuit. The pump control time is retarded by means of throttles.

The DA control is designed for mobile transmissions with combustion engines. It takes account of the fact that in combustion engines the torque increases with the speed, and that with loads around the max. torque limit a loss of speed occurs. The power capacity of a combustion engine can, therefore, more or less be equated with its current speed. Through corresponding adjustments on the hydraulic side, optimum automotive control is achieved.

High Pressure Range 400/450 bar

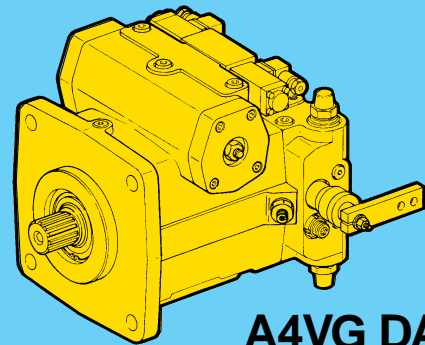

A4VG DA

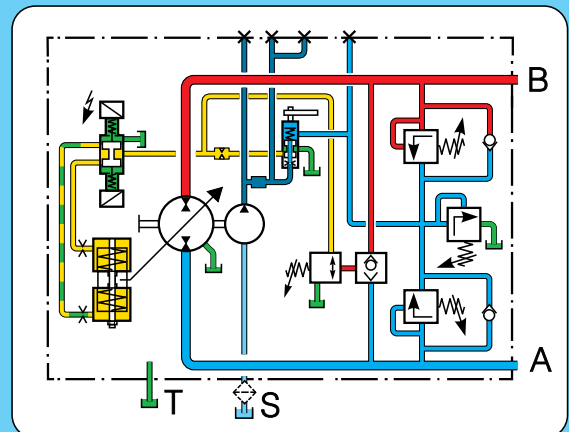

3.9 Fixed Motor of Swashplate Design

The A4FM is of compact, space-saving design, offering the following technical advantages with:

Connection in series (summed pressure)
 Mounting of brake possible
 Insensitive to oscillations

This fixed motor for high pressures (350/400 bar) is suitable for connection in series. The axial pressure compensation of the hydrostatic bearing on the slipper pads ensures high loading capability and a long service life.

350/400 bar



A4FM

3.10 Variable Motor of Swashplate Design

The A10VM is a switching motor in swashplate design that can be switched between two positions.

It operates in the medium pressure range (250/315 bar) in open or closed circuits.

Variable motor/switching motor
 Hydraulic or electrical two-point adjustment
 with mounted switching valve

Adjustment range 1 : 2,5

Mechanical holding brake can be built on

Also available as a small compact plug-in motor

250/315 bar



A10VM

3.11 Summary of the most common control options on pumps and motors

The electronic components (amplifiers), used to amplify the signals, are not listed here.

Different features of the controls are:

- type of circuit
- force transfer (hydraulic or mechanical)
- operation of control (direct or pilot operation)
- curve (position and adjustability)
- open loop control (without feedback)
 - mechanical/manual
 - mechanical/electrical
 - hydraulic/mechanical
 - hydraulic/electrical
 - hydraulic/hydraulic
- closed loop control (with feedback)
 - hydraulic/mechanical
 - hydraulic/electrical

3.11.1 Pump Controls

■ Mechanical - manual, proportional to:

MA - control stroke s , or

MD - control angle β for pumps in reversible operation

■ Mechanical/electrical, with

EM - electric gear motor

MA
manual control

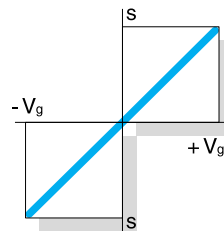

MD
mechanical pivot pin control

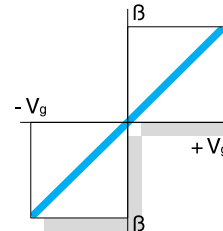

EM
electric motor control

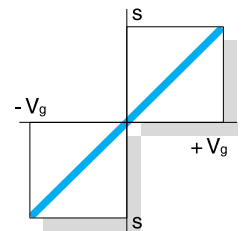

V_g = specific displacement s = control stroke β = control angle

■ Hydraulic - mechanical, proportional to:

DG - pilot pressure p_{st}

HW - control angle β , or control stroke s for pumps in reversible operation

DG
direct operated hydraulic control pressure related

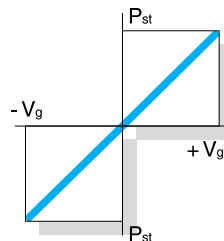

HW
hydraulic control stroke related ¹⁾

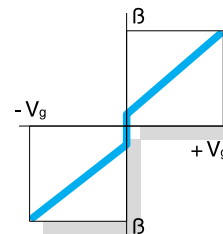

HW
hydraulic control stroke related

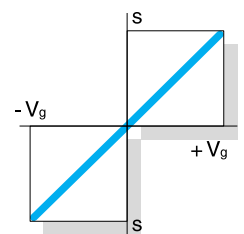

V_g = specific displacement p_{st} = pilot pressure ¹⁾ = dead band in zero position

- Hydraulic - hydraulic:
 - HD** - proportional to pilot pressure p_{st} for pumps in open circuit or reversible operation

HD
hydr. control pressure related

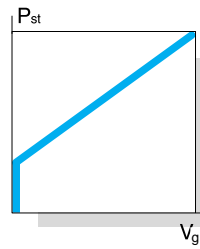

HD
hydr. control pressure related ¹⁾

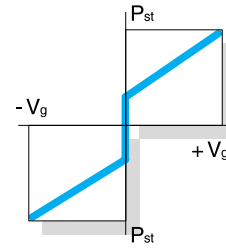

HD
hydr. control pressure related

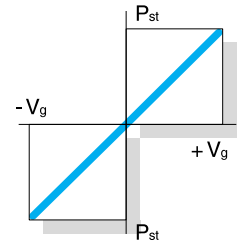

V_g = specific displacement p_{st} = pilot pressure ¹⁾ = dead band in zero position

- Hydraulic - electrical:
 - EZ** - with switching solenoids (not illust.)
 - EP** - with proportional solenoids, proportional to control current I in open or closed circuit
 - ES** - with servo valve in closed circuit

EP
electric control with proportional solenoid

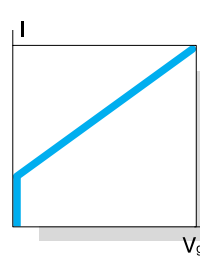

EP
electric control with proportional solenoid

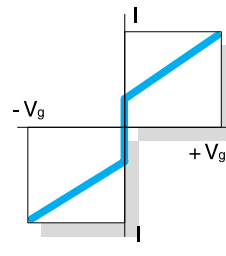

ES
electric control with servo valve

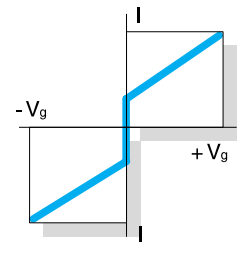

V_g = specific displacement I = control current

- Hydraulic, flow-related:
 - HM** - proportional to pilot oil flow V_s , in reversible operation
 - HS** - electrical/hydraulic with built-on servo valve, proportional to control current I

HM
hydr. control flow-related

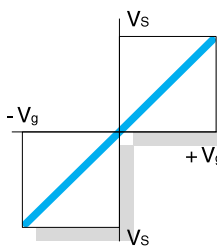

HS
hydr. control with servo valve

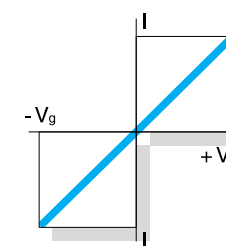

V_g = specific displacement V_s = pilot oil flow

- Hydraulic, flow-related:
 - EO** - with built-on proportional valve in reversible operation; with electronic amplifier; closed loop control possible.

EO
electronic control

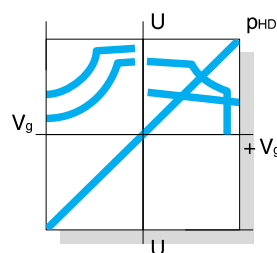

U = control voltage p_{HD} = high pressure

3.11.2 Closed-Loop Pump Controls

■ Hydraulic:

DR - constant system pressure through suitable adjustment of pump flow

FR - constant pump flow with variable drive speed and/or flow variation to meet changing user requirement

DFR - a combination of both the above controls; the constant flow control is super-imposed on a mechanically settable constant pressure control

DR
constant pressure control

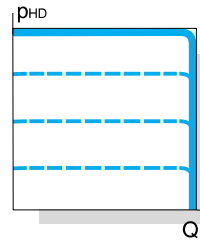

FR
constant flow control

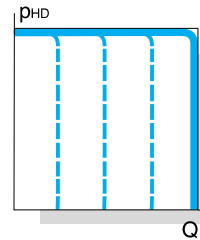

DFR
const. pressure and flow control

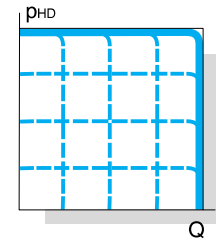

Q = flow

p_{HD} = high pressure

LR - constant drive torque control; power = torque x speed, $P = M \times n = \text{constant}$.

SR - for parallel operation of two pumps from one prime mover; automatic power distribution by summation of pressure

DFLR - combined constant pressure/flow control with super-imposed constant horsepower control

LR
constant HP control

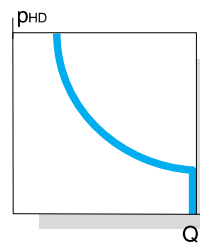

SR
summed HP control

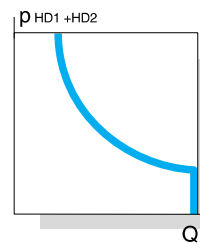

DFLR
const. pressure, HP and flow control

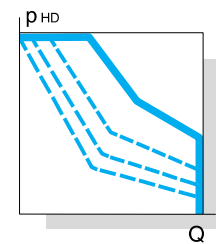

V_g = specific displacement

Q = flow

p_{HD} = high pressure

DRS - flow variation according to user requirement (load sensing) with super-imposed constant pressure control; pump is swivelled dependent on load pressure

LRDS - drive torque is limited on max. by addition of constant horsepower control; pump flow is varied according to user requirement

■ Electronic:

DFE - alternative electronic version of combined control DFR.

DRS
const. pressure control with load sensing

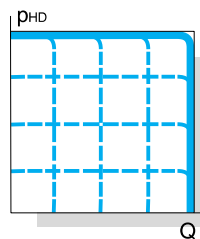

LRDS
const. HP control with pressure cut-off and load sensing

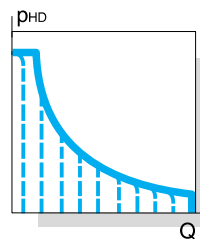

DFE
electronic const. pressure and flow control

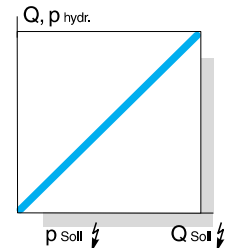

V_g = specific displacement

p_{HD} = high pressure

⚡ = electric signal

3.11.3 Motor Controls

- Hydraulic - hydraulic:
 - HD** - proportional to pilot pressure p_{st} .
 - HZ** - hydraulic/hydraulic, two-point control
 - EP** - hydraulic/electric, with proportional solenoid
 - EZ** - with switching solenoid, two-point control.

HD
hydr. control, pilot-pressure-related

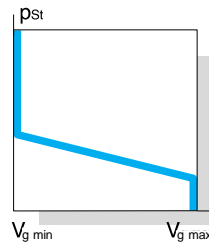

HZ
hydr. two-point control

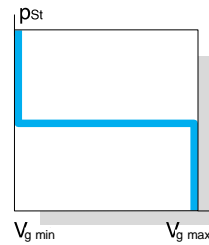

EP
electrical control with proportional solenoid

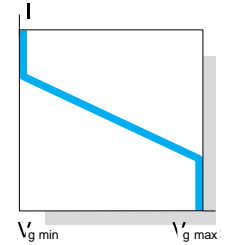

EZ
electrical two-point control with switching solenoid

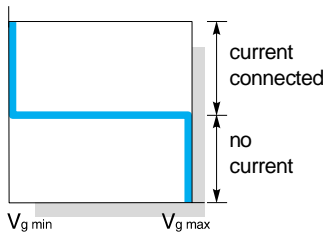

V_g = specific displacement p_{st} = pilot pressure I = control current

3.11.4 Closed-Loop Motor Controls

- Hydraulic:
 - HA** - automatic high-pressure-related control; automatic adjustment to current torque requirement
 - DS** - pumps with DS control are used as motors for "secondary control"
 - DA** - speed-related hydraulic control is the basis for "mobile transmission" with "automotive control".

HA
automatic control high pressure related

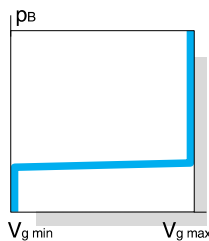

DS
constant speed control, with secondary control

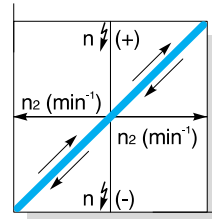

DA
hydr. control speed related

V_g = specific displacement p_B = operating pressure n = speed